



Avery Weigh-Tronix

SCALES FOR AGRIBUSINESS



Model 2040/2040XL Indicator Service Manual

Table of Contents

Table of Contents	3
Specifications	4
Introduction	7
Setup Menu (2040 password)	7
To Access the Setup Menu (2040)	7
Setup Menu Items	9
CONFIG	9
CUSTOM	9
O-CAP	11
SPAN	11
M-DOOR	12
CLOCK	12
NAME	13
ALARM	13
INPUT.1	14
INPUT.2	14
UPDATE	14
AVERAGE	15
FILTER	15
AZT	16
MOTION	17
RS232.1/RS232.S	17
Test (111) Menu	21
Access the Test Menu	21
Test Menu Items	22
Setting Factory Defaults	27
Production or Service Factory Calibration	27
Accessing Factory Calibration Mode	27
Setting Zero Calibration	27
Setting the Span Calibration	28
Viewing Current Calibration	28
Viewing Factory Span Factor	28
Re-setting Factory Span Without Calibrating with a Simulator	29
Technical Drawings	31

Specifications

Power Input:	10 to 18 volts, DC negative ground 400ma at 8 350 weigh-bar load
Display:	2.0 inch LCD (Model 2040), 6 Digits, 14 segment alpha-numeric, fiber optic backlight
Display Rate:	1, 2, or 5 times per second
Enclosure:	Water/dust resistant, structural polycarbonate, 8.50" high x 10.5" wide x 6.0" deep IP65 Water resistant
Capacity Range:	Up to 200,000 lb/kg
Increment sizes:	.01,.02,.05,.1,.2,.5,1,2,5,10,20,50,100,200 lb/kg
Accuracy:	+/- 0.1 % of applied load +/- 1 division
Internal A/D resolution:	1,000,000 counts
Operational keys:	0-9 with alpha capabilities, Load/Unload, Gross, Recipe, Usage, Hold, Menu, Print, Id, Select, Timer, Cleanup and Zero Clear
Annunciators;	Auto, Pen, Load, Gross, Recipe, Ingredient, Alarm, Usage, Cleanup, Hand-Add, Lb, and Kg. (12 annunciators)
Audio Output:	Audio tone feedback for key contact assurance
Weigh-bar Drive:	10 350 ohm weigh-bars
Serial Ports:	2 RS-232 serial ports programmable for different selectable output formats (Std, TDM, Broadcast, or Feed Supervisor)
Lower Assembly:	Connectors for the following: Power, Com1, Com 2, Weigh-bar J-box, Alarm Output, RD64 Optional Connectors:Speed Sensor Input There will be seven standard different lower base assemblies: 1. W/T standard 7 pin 5 conn (pwr/alm/RD64/Com1/j-box) 2. W/T std 7 pin w/options 7 conn (pwr/alm/speed/RD64/Com1/Com2/j-box) 3. Single conn (AMP) 5 conn (pwr/alm/RD64/Com1/j-box) 4. Single conn (AMP w/options) 7 conn (pwr/alm/speed/RD64/Com1/Com2/j-box) 5. *W/T 4 x 5pin w/ Com 1 and RD64 output 8 con (pwr/alm/RD64/Com1/4-5 pin conn) 6. *W/T 3 x 5pin w/dual RS-232 and RD64 output 7 conn (pwr/alm/RD64/Com1/3-5 pin conn) 7. *W/T 4 x 4pin w/dual RS-232 and RD64 output 8 conn (pwr/alm/RD64/Com1/4-4pin conn) *NOTE: These versions do not offer Speed Sensor input or com 2.

Two TTL Inputs: Two programmable inputs (Std, Zero Clear, Menu, Hold, Print)

Options:

Feed Supervisor software packages

RD64XL Remote Display

RD125RF Remote Display

XM64 Transmitter/receiver set

RFT-02 Wireless Data transfer

Speed Sensor switch assembly

Operating Temperature: -40° to 140° F (-40° to 60° C)

Weight: 10 lb/ 4.5 kg

Agencies: FCC Class A
CE (European Approval)

Warranty: Three Year

Introduction

This manual covers the setup and servicing of the Model 2040 indicator.

The first part of the manual covers the configuring of the indicator using menus you access through the front panel keys.

- Setup Menu (2040 password)
- Test Menu (111 password)
- History Menu (999 password)
- Calibration Menu (010101 password)

The last part of the manual covers the parts and assemblies of the indicator.

Setup Menu (2040 password)

The Setup menu is shown in Figure 1. Following are the different parameters that can be configured under the Setup menu:

CONFIG	To enter the 4-5 digit configuration number
CUSTOM	Enter a weight value at .4 mv/v
O-CAP	Sets the over-capacity value of the scale. When reached display shows -----
SPAN	Used to adjust the span +/- 10 %.
M-DOOR	Turns the mixer door feature on/off.
CLOCK	To set the clock to either 12 or 24 hour clock
NAME	To set the point where ingredient name stops flashing
ALARM	To set the pre-alarm target value (percent or weight)
INPUT.1	To set input 1 for std, zero, menu, hold, or print
INPUT.2	To set input 2 for std, zero, menu, hold, or print
UPDATE	Configure the indicator for 1,2, or 5 display updates/second
AVERGE	Configure the indicator for the # of A/d conversions (1-60)
FILTER	Configure the harmonizer filter and threshold
A.Z.T.	Configure the Automatic Zero Tracking. (off to 10.0 divisions)
STABLE	Configure the motion window (off to 10.0 divisions)
RS232.1	Configure the RS232 serial port 1 (baud, parity, data, hand, auto, or layout)
RS232.2	Configure the RS232 serial port 2 (baud, parity, data, hand, auto, or layout)

To Access The Setup Menu (2040)

1. From the gross mode, press and hold the **MENU** key for three beeps (3 seconds), then release. . .
SET.PAS is displayed.
2. Key in 2040. .
**** is displayed
3. Then press the **SELECT** key. . .
CONFIG is displayed.

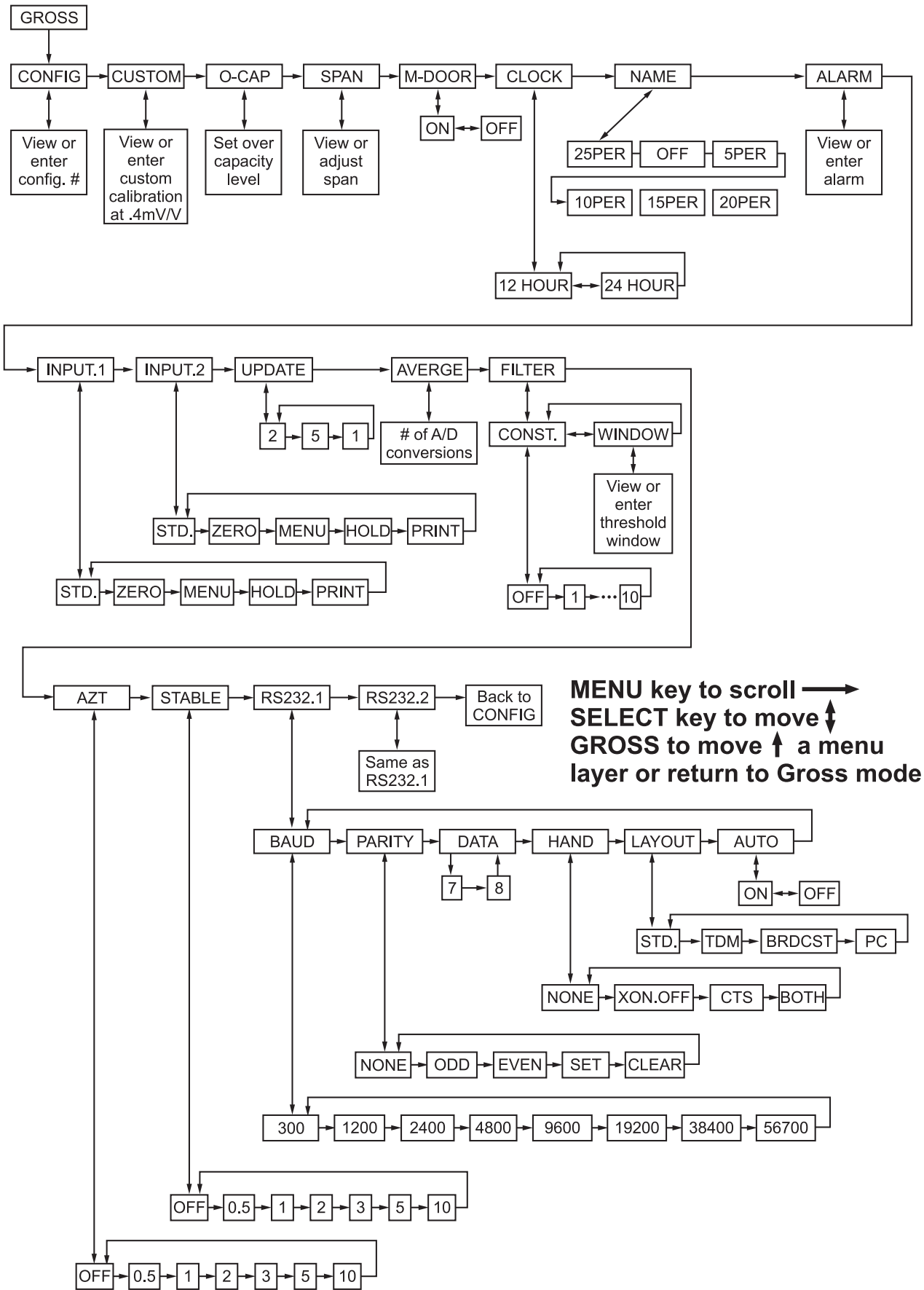

Figure 1
Setup menu

Setup Menu Items

CONFIG

If you are using a custom weight sensor, see the next item, CUSTOM, to help you pick the correct first three digits of your configuration number.

*You must press **SELECT** to actually store the CONFIG #. Pressing **GROSS** here will only return to Gross mode.*



The first menu item is **CONFIG**. This allows you to enter a 4-5 digit configuration number that sets up the indicator for the type of Weigh Bar, capacity, increment, pre-alarm mode, units, auto hold, and auto-mix.

Determine the correct configuration number for your system by using the table in Figure 2.

Example:

20,000 x 5 lb, 2 1/8 calibration, pre-alarm in weight with audible beeper, auto hold /auto-mix on, = 5233

Once a number is established simply enter as follows:

1. From **CONFIG**, press **SELECT**. . .
Current code number is shown.
2. Use the keypad, enter configuration number. . .
Entered number is shown. If attempting to enter an invalid number display will show **CAN't** and return to **CONFIG**.
3. Press **SELECT**. . .
CONFIG is shown.
4. Press the **GROSS** key. . .
Returns to the Gross Weighing mode.

CUSTOM

*If you press **SELECT** and the 2040 does not have a CONFIG# starting with 97, 98, or 99, the display will show **CAN'T**.*

The next item is **CUSTOM**. If you are using a custom weight sensor, the mv/v rating of the system needs to be known. You need to convert the values so you know what the weight value is at 0.4 mv/v. This weight value is then entered into the Model 2040. You can then look at the CONFIG chart in Figure 2 and decide if the code number would start with a 97, 98, or 99 configuration number.

EXAMPLE: If your custom system capacity is 2 mv/v at 20000 lb, when this is converted to weight at .4 mv/v, it comes to 4000 lb. Check out the math below:

$$2 \text{ mv/v at } 20000 \text{ lbs} = .4 \text{ mv/v at } 4000 \text{ lbs}$$

$$\frac{2 \text{ mv/v}}{.4 \text{ mv/v}} = 5 \rightarrow \frac{20000}{5} = 4000$$

4000 is the value to be entered in this menu item.

1. From the **CONFIG** display, press menu once. . .
CUSTOM is shown
2. Press the **SELECT** key. . .
current weight value is shown

Default value of custom = 20000, or 0.4 mv/v at 20,000 lb.

Figure 2
Configuration number chart

1st #	CALIBRATION SIZE	CAPACITY x INCREMENT SIZE					
00	5/8 *	200 x 0.01	200 x 0.02	200 x 0.05	2K x 0.1	2K x 0.2	2K x 0.5
01	1	2K x 0.1	2K x 0.2	2K x 0.5	20K x 1	20K x 2	20K x 5
02	1-1/4	2K x 0.1	2K x 0.2	2K x 0.5	20K x 1	20K x 2	20K x 5
03	1-7/8	20K x 1	20K x 2	20K x 5	200K x 10	200K x 20	200K x 50
04	2	20K x 1	20K x 2	20K x 5	200K x 10	200K x 20	200K x 50
05	2-1/8	20K x 1	20K x 2	20K x 5	200K x 10	200K x 20	200K x 50
06	2-1/4	20K x 1	20K x 2	20K x 5	200K x 10	200K x 20	200K x 50
07	2-1/4D	20K x 1	20K x 2	20K x 5	200K x 10	200K x 20	200K x 50
08	2-1/4D-P	200K x 10	200K x 20	200K x 50	200K x 100	200K x 200	200K x 500
09	2-1/2	20K x 1	20K x 2	20K x 5	200K x 10	200K x 20	200K x 50
10	3-1/8	200K x 10	200K x 20	200K x 50	200K x 100	200K x 200	200K x 500
11	4	200K x 10	200K x 20	200K x 50	200K x 100	200K x 200	200K x 500
12	CC20/CC30 (2.13mV/V)	20K x1	20K x 2	20K x 5	200K x 10	200K x 20	200K x 50
13	Alley Weigh	2K x 0.1	2K x 0.2	2K x 0.5	20K x 1	20K x 2	20K x 5
14	CC30-3 (3mV/V)	20K x 1	20K x 2	20K x 5	200K x 10	200K x 20	200K x 50
18	SPARE	20K x 1	20K x 2	20K x 5	200K x 10	200K x 20	200K x 50
20	1 (DIGI)	2K x 0.1	2K x 0.2	2K x 0.5	20K x 1	20K x 2	20K x 5
21	1 POLY(DIGI)	20K x 1	20K x 2	20K x 5	200K x 10	200K x 20	200K x50
22	1-7/8,2(DIGI)	20K x 1	20K x 2	20K x 5	200K x 10	200K x 20	200K x 50
23	2-1/8,2-1/2, 2-7/8,3-3/4 (DIGI)	20K x 1	20K x 2	20K x 5	200K x 10	200K x 20	200K x 50
97	Custom Setting	200 x 0.01	200 x 0.02	200 x 0.05	2K x 0.1	2K x 0.2	2K x 0.5
98	Custom Setting	20K x 1	20K x 2	20K x 5	200K x 10	200K x 20	200K x 50
99	Custom Setting	200K x 100	200K x 200	200K x 500			
	2nd #	0	1	2	3	4	5

3rd #	Warning Alarm Method
0	OFF
1	WEIGHT
2	PERCENT
3	WEIGHT w/AUDIBLE ALARM
4	PERCENT w/AUDIBLE ALARM

The actual warning pre-alarm value is entered within the ALARM setting as weight or percentage based on actual configuration number. ALARM is located in the 2040 MENU. (Default is 50 lb)

4th #	units	Auto-hold	Auto-mix	4th #	units	Auto-hold	Auto-mix
0	Lb	Off	Off	5	Kg	Off	On
1	Lb	Off	On	6	Kg	On	Off
2	Lb	On	Off	7	Kg	On	On
3	Lb	On	On				
4	Kg	Off	Off				

O-CAP

3. Use the keypad to enter in the calculated custom number. . .
Entered number is shown.
4. Press the **SELECT** key. . .
CUSTOM is shown.
5. Press the **GROSS** key to return to the Gross weighing mode.

The next item is **O-CAP**. Use this to set the overcapacity of the 2040 if the standard default of 200.00, 2000.0 ,20000, or 200000 is not acceptable.

If you select 20,000 x 5, but really want a 25000 x 5, enter 25000 under this menu item. If this parameter is not used it will default to what was set in the **CONFIG** parameter.

1. From the **CONFIG** display, press the **MENU** key several times until. . .
O-CAP is displayed.
2. Press the **SELECT** key. . .
Current over capacity parameter is shown.
3. Using the keypad, enter in the overcapacity. . .
New over capacity value is displayed.
4. Press the **SELECT** key. . .
O-CAP is displayed.
5. Press the **GROSS** key to return to the Gross weighing mode.

SPAN

The next item is **SPAN**. The indicator has two ways of adjusting span.

- A. Use the **SPAN** item and adjust the weight span reading by +/- 10%.
 - B. Use a custom code and change the sensitivity number accordingly to change the span. (Example: If you need to adjust the span down by 5%, move the custom weight number down by 5%).
1. From the **CONFIG** display, press the **MENU** key several times until . . .
SPAN is displayed.
 2. Press the **SELECT** key. . .
Current weight is displayed.
 3. With either a calibrator or some known weight on the scale system put appropriate weight onto the scale system.
Current weight is displayed.

If adjustments differ from factory settings, when you access the CONFIG# *5233 will be displayed.

4. Use the keypad, adjust weight accordingly:
 - To increase span, press 1,2,4,5
 - To decrease span, press 6,7,9,0
 - To return to the span factory calibrated value, press 3 or 8.

Each press of a key will decrement/increment one division of the scale. If you press and hold the key, weight will decrease/increase faster.

5. Once appropriate weight value is shown, press the **SELECT** key. . .
SPAN is shown.
6. Press the **GROSS** key to return to the Gross weighing mode.

M-DOOR

The next item is **M-DOOR**. Use this to enable or disable the mixer door position feature.

1. From the **CONFIG** display, press the **MENU** key repeatedly until. . .
M-DOOR is displayed.
2. Press the **SELECT** key. . .
OFF is shown.
3. Press the **MENU** key to toggle between **ON** and **OFF**. When your choice is displayed, press the **SELECT** key. . .
M-DOOR is displayed.
4. Press the **GROSS** key to return to the Gross weighing mode.

CLOCK

The next item is **CLOCK**. Use this to set the clock in either 12 or 24 hour format. Default is 12 hour format.

1. From the **CONFIG** display, press the **MENU** key repeatedly until. . .
CLOCK is displayed.
2. Press the **SELECT** key. . .
12 HR is shown.
3. Press the **MENU** key. . .
24 HR is shown.
4. Pressing **MENU** key alternates between 12/24 hour setting. Once the proper selection is displayed press **SELECT**. . .
CLOCK is displayed.
5. Press the **GROSS** key to return to the Gross weighing mode.

NAME

The next item is **NAME**. Use this to set the percentage at which the ingredient name stops flashing in the Recipe mode.

1. From the **CONFIG** display, press the **MENU** key repeatedly until. . .
NAME is displayed.
2. Press the **SELECT** key. . .
25PER is shown.
3. Press the **MENU** key to scroll through list.
4. Press **SELECT** when your choice is displayed.
NAME is displayed.
5. Press the **GROSS** key to return to the Gross weighing mode.

ALARM

The next item in the menu is **ALARM**. Use this to set the point at which the alarm begins to flash in the load/unload modes. Default value is 50.

If you enter 30 and the code number sets the indicator for weight, then the alarm will start flashing 30 lb before the target is met. If set for percent, the alarm will start flashing when within 30% of the target.

1. From the **CONFIG** display, press the **MENU** key repeatedly until. . .
ALARM is displayed.
2. Press the **SELECT** key. . .
Current alarm setting is shown
3. Use the keypad, and enter in the custom alarm value. . .
Entered value is shown.
4. Press the **SELECT** key. . .
ALARM is shown.
5. Press the **GROSS** key to return to the Gross weighing mode.

INPUT.1 (XM64)

The next item is **INPUT.1**. Use this to set the function of INPUT.1. Default is STD. This parameter allows user to set the function of input.1, or the XM64. The selections are as follows”

STD, ZERO, MENU, HOLD, or PRINT.

The **STD** selection means the following:

- If in the 0 Load/Unload mode, activating the input allows the tare/viewing of the Gross weight to take place.
- If in the RECIPE/Pen mode, activating the input allows the ingredient/pen advance, or activates like the MENU key.

ZERO, MENU, HOLD, PRINT, act exactly like the keys themselves.

1. From the **CONFIG** display, press the **MENU** key repeatedly until . . .
INPUT.1 is displayed.
2. Press the **SELECT** key. . .
current setting is shown
3. Using the **MENU** key, once the proper setting is displayed, press **SELECT**. . .
INPUT.1 is displayed.
4. Press the **GROSS** key to return to the Gross weighing mode.

INPUT.2 (Spare)

The next item is **INPUT.2**. Use this to set the function of INPUT.2. Default is STD. This item is just like INPUT.1. Follow the same steps to set INPUT.2.

UPDATE

The next item is **UPDATE**. Use this to set the display update rate. Choose from updates 1, 2, or 5 times /second. Default is 2 times/sec.

1. From the **CONFIG** display, press the **MENU** key repeatedly until. . .
UPDATE is displayed.
2. Press the **SELECT** key. . .
current selection is displayed.
3. Use **MENU** key to move to proper selection, then press the **SELECT** key. . .
UPDATE is displayed.
4. Press the **GROSS** key to return to the Gross weighing mode.

AVERGE

If you attempt to enter A/D conversions higher than 60, a value of 60 will be set automatically.

The next item is **AVERGE**. Use this to set the number of A/D conversions to average. Default is 30.

For example if you enter in 30, the unit will average the weight values from the last 30 A/D conversions and uses that value for displayed data. (Accepts values from 1-60)

1. From the **CONFIG** display, press the **MENU** key repeatedly until . . .
AVERGE is displayed.
2. Press the **SELECT** key. . .
current selection is displayed.
3. Use the keypad enter the number of conversions. . .
entered number is displayed
4. Press the **SELECT** key. . .
AVERGE is displayed.
5. Press the **GROSS** key to return to the Gross weighing mode.

FILTER

The next item is **FILTER**. Use this to enable and configure the Harmonizer™ filtering.

If you program in a value for the constant other than off, then the Harmonizer is on, and you must also enter a threshold value. If the constant = off, then the Harmonizer filtering is not engaged. Set the number low for small vibration problems and higher for more dampening effect.

The purpose of the Harmonizer Threshold is so the indicator will respond quickly to large weight changes. Harmonizer Threshold is the amount of weight change, in calibration units, beyond which the Harmonizer will be temporarily disabled. For example, if you set this to 10 lbs, a weight change over 10 pounds occurring during the display time will disable the Harmonizer until the weight change during the sample time drops below 10 lbs.

1. From the **CONFIG** display, press the **MENU** key repeatedly until . . .
FILTER is displayed
2. Press the **SELECT** key. . .
CONST is displayed
3. Press the **SELECT** key. . .
Current harmonizer setting is displayed.
4. Use **MENU** key until proper const. is shown.
Value is shown

5. Press the **SELECT** key. . .
CONST. is shown.
6. Press the **MENU** key. . .
WINDOW is shown.
7. Press the **SELECT** key. . .
Current threshold is displayed.
8. Use the keypad, enter the new value. . .
Entered value is shown. (ENTERED VALUE MUST BE LOWER THAN THE SCALE CAPACITY)
9. Press the **SELECT** key. . .
WINDOW is shown
10. Press the **GROSS** key. . .
FILTER is displayed
11. Press the **GROSS** key to return to the Gross weighing mode.

The next item is **AZT**. Use this to set the Automatic Zero Tracking window, with the following choices:

OFF, 0.5 , 1.0, 2.0, 3.0, 5.0, 10.0 divisions

Default setting is OFF.

1. From the **CONFIG** display, press the **MENU** key repeatedly until. . .
AZT is displayed.
2. Press the **SELECT** key and. . .
current selection is shown
3. Use the **MENU** key and move to the proper selection. . .
proper choice is shown
4. Once proper choice is shown, press **SELECT**. . .
AZT is shown
5. Press the **GROSS** key to return to the Gross weighing mode.

AZT

MOTION

The next item is **MOTION**. Use this to set the motion window, with the following choices:

off, 0.5, 1.0, 2.0, 3.0, 5.0, 10.0 divisions

Default is OFF

1. From the **CONFIG** display, press the **MENU** key repeatedly until. . .
MOTION is displayed.
2. Press the **SELECT** key and. . .
current selection is shown
3. Use the **MENU** key and move to the proper selection. . .
proper choice is shown
4. Once proper selection is shown, press the **SELECT** key. . .
MOTION is shown
5. Press the **GROSS** key to return to the Gross weighing mode.

RS232.1 RS232.2

Note: Port 1 must be used with the Feed Supervisor pc package.

The last items are the serial ports which are labeled **RS232.1** and **RS232.2**. Use these items to set the serial communication protocols.

RS232.1 represents com port 1

RS232.2 represents com port 2

Setting The Baud Rate

Default baud rate is 9600.

1. From the **CONFIG** menu, press the **MENU** key repeatedly until. . .
RS232.1 is shown
2. Press the **SELECT** key. . .
BAUD is shown
3. Press the **SELECT** key. . .
Current baud rate is shown
4. Use the **MENU** key to scroll to the proper selection. . .
Proper selection is shown
5. Press the **SELECT** key. . .
BAUD is shown.
6. Press the **GROSS** key. . .
RS232.1 is shown
7. Press the **GROSS** key to return to the Gross weighing mode.

Note: The baud should be set to 19200 when the Feed Supervisor package is in use.

Setting The Parity Selection

The default parity setting is NONE.

1. From the **CONFIG** menu, press the **MENU** key repeatedly until. . .
RS232.1 is shown
2. Press the **SELECT** key. . .
BAUD is shown
3. Press the **MENU** key. . .
PARITY is shown
4. Press the **SELECT** key. . .
Current selection is shown.
5. Use the **MENU** key to scroll to the proper selection. . .
Proper selection is shown.
6. Press the **SELECT** key. . .
PARITY is shown
7. Press the **GROSS** key. . .
RS232.1 is shown
8. Press the **GROSS** key to return to the Gross weighing mode.

Setting The Data Bits

The default is 8 data bits.

1. From the **CONFIG** menu, press the **MENU** key repeatedly until. . .
RS232.1 is shown
2. Press the **SELECT** key. . .
BAUD is shown
3. Press the **MENU** key repeatedly until. . .
DATA is shown
4. Press the **SELECT** key. . .
Current selection is shown.
5. Use the **MENU** key to scroll to the proper selection. . .
Proper selection is shown.
6. Press the **SELECT** key. . .
DATA is shown
7. Press the **GROSS** key. . .
RS232.1 is shown.
8. Press the **GROSS** key to return to the Gross weighing mode.

Setting The Handshaking

Note: The handshaking should be set to Xon.Xoff when the Feed Supervisor package is in use.

Default setting is NONE.

1. From the **CONFIG** menu, press the **MENU** key repeatedly until. . .
RS232.1 is shown
2. Press the **SELECT** key. . .
BAUD is shown
3. Press the **MENU** key repeatedly until. . .
HAND is shown
4. Press the **SELECT** key. . .
Current selection is shown.
5. Use the **MENU** key to scroll to the proper selection. . .
Proper selection is shown.
6. Press the **SELECT** key. . .
HAND is shown
7. Press the **GROSS** key. . .
RS232.1 is shown
8. Press the **GROSS** key to return to the Gross weighing mode.

Setting The Com Port Serial Data Layout

The default setting is STD.

The following parameters can be set as follows:

STD: All printouts will be printed as standard, and auto printing at the end of batch will work if enabled.

FSUPER: The port must be in this mode when using the Feed Supervisor pc package to transfer information.

BRDCST: Broadcast continuous serial RS-232 data so this can be hooked up to an RD125RF unit.

GROSS: Continuous displayed weight data
LOAD/UNLOAD: Continuous displayed load/unload values
RECIPE: Gross weight until the RECIPE is activated and the same information being displayed on the Model 2040 needs to be transferred.

TIMER: Transfer the same Model 2040 displayed information in this mode.

PEN: Transfer the same Model 2040 displayed information in this mode.

1. From the **CONFIG** menu, press the **MENU** key repeatedly until. . .
RS232.1 is shown
2. Press the **SELECT** key. . .
BAUD is shown

3. Press the **MENU** key repeatedly until. . .
LAYOUT is shown
4. Press the **SELECT** key. . .
Current selection is shown.
5. Use the **MENU** key to scroll to the proper selection. . .
Proper selection is shown.
6. Press the **SELECT** key. . .
LAYOUT is shown
7. Press the **GROSS** key. . .
RS232.1 is shown
8. Press the **GROSS** key to return to the Gross weighing mode.

Setting The Auto Print Feature

*This parameter only works if
Layout is set to STD.*

Default setting is OFF.

This selection needs to be turned on when wanting an automatic printing of batched data when using the Recipe/Pen batching features.

1. From the **CONFIG** menu, press the **MENU** key repeatedly until. . .
RS232.1 is shown
2. Press the **SELECT** key. . .
BAUD is shown
3. Press the **MENU** key repeatedly until. . .
AUTO is shown
4. Press the **SELECT** key. . .
Current selection is shown.
5. Use the **MENU** key to scroll to the proper selection. . .
Proper selection is shown.
6. Press the **SELECT** key. . .
AUTO is shown
7. Press the **GROSS** key. . .
RS.232.1 is shown
8. Press the **GROSS** key to return to the Gross weighing mode.

TEST (111) MENU

The test menu is a basic menu for self diagnostics. You can use this to test certain functions of the indicator.

- VOLTS Monitor the input voltage of the indicator
- LCD Do an LCD display test.
- KEYPAD Do a keypad test
- A / d Do an Analog to Digital Test (A/D)
- SERIAL Check the serial ports (Ports 1 and 2).
- INPUTS Check the 7 TTL inputs.
- RELAY Check the alarm relay
- SOFT Verify the software version of the indicator.

The Test menu is shown in Figure 3.

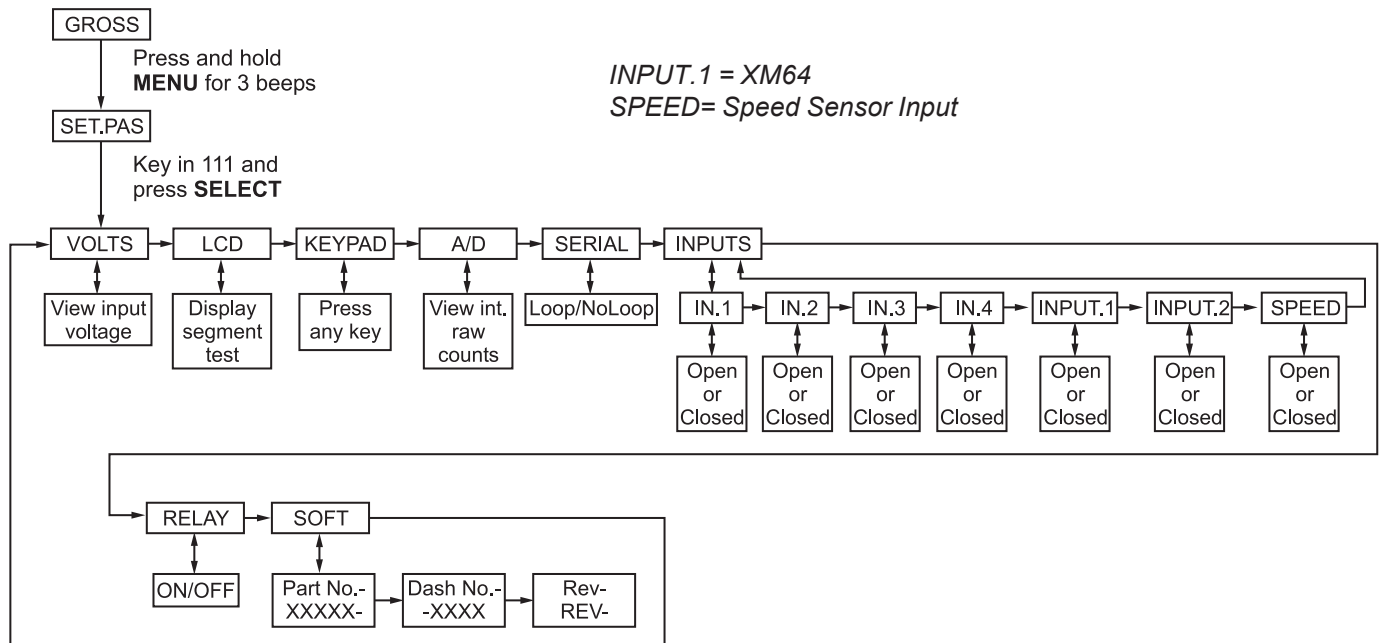

Figure 3
Test menu

Access the Test Menu

1. From the Gross mode press and hold the **MENU** key for three beeps (3 seconds), then release. . .
SET.PAS is displayed.
2. Use the keypad to enter '111'. . .
*** is displayed
3. Then press the **SELECT** key. . .
VOLTS is displayed.

Test Menu Items

VOLTS (Input Voltage)

Following are the Test menu items and their explanations.

This allows a user to check the 12VDC input voltage that the Model 2040 is operating on.

1. Access the test menu. . .
VOLTS is displayed.
2. Press the **SELECT** key. . .
Current voltage is displayed.
3. Press the **SELECT** key . . .
VOLTS is displayed
4. Press the **GROSS** key to return to the Gross weighing mode.

LCD (LCD Display Test)

This test does a self test on the LCD , either a complete display test or a segment test.

1. From **VOLTS** press **MENU**. . .
LCD is displayed.
2. Press the **SELECT** key. . .
TEST is shown.
3. Press the **SELECT** key. . .
Display performs a display test (15 sec).
4. When test is completed. . .
TEST is shown.
5. Press **MENU**. . .
SEGMNT is displayed.
6. Press the **SELECT** key. . .
Display performs a segment test (70 sec)
7. When test is completed. . .
SEGMNT is displayed.
8. Press **GROSS** key to. . .
Return to **LCD** display.
9. Press the **GROSS** key to return to the Gross weighing mode.

KEYPAD (Keypad Test)

*If a key is bad and the unit is turned ON, BAD.KEY will be displayed after 10 seconds. If the 2040 can detect, for example, that key 6 is faulty, the display will flash **BAD.KEY 6**.*

This test allows testing of all active keys. . .

1. From **VOLTS**, press **MENU**. . .
LCD is displayed.
2. Press the **MENU** repeatedly until. . .
KEYPAD is shown.
3. Press **SELECT**. . .
HIT.KEY is displayed

NO KEY is shown if a key isn't being pressed. Below is the list of keys and what appears if you press that key:

KEY	DISPLAY
1	1
2	2
3	3
4	4
5	5
6	6
7	7
8	8
9	9
0	0
RECIPE	RECIPE
GROSS	GROSS
LOAD/UNLOAD	LOAD
PEN	PEN
HOLD	HOLD
TIMER	TIMER
ZERO	ZERO
PRINT	PRINT
USAGE	USAGE
ID	ID

4. Press the **MENU** key. . .
Display returns to **KEYPAD** display.
5. Press the **GROSS** key to return to the Gross weighing mode.

A/D (A to D Counts and mV/V Test)

The test allows you to see the A to D raw counts and the current mV/V reading.

1. From **VOLTS**, press **MENU**. . .
LCD is displayed.
2. Press **MENU** repeatedly until. . .
A/D is shown
3. Press the **SELECT** key. . .
CNTS is shown momentarily and then the actual A/D raw counts is shown.
4. Press the **SELECT** key. . .
MV/V is shown momentarily and then the actual mV/V reading is shown.
5. Press the **SELECT** key. . .
A/D is shown.
6. Press the **GROSS** key to return to the Gross weighing mode.

SERIAL (Serial Port Test)

This test allows you to check the serial ports for proper operation.

1. From **VOLTS**, press **MENU**. . .
LCD is displayed.
2. Press **MENU** repeatedly until. . .
SERIAL is shown
3. Press the **SELECT** key and . . .
PORT 1 is displayed
4. Press the **SELECT** key and . . .
NOLOOP is displayed
5. Short the XMT to RCV (Pins 2 and 4) and. . .
LOOP will be displayed.
6. Press **SELECT** and. . .
PORT 1 is displayed.
7. Press the **MENU** key. . .
PORT 2 is displayed.
8. Repeat steps 4-6 . . .
PORT 2 is displayed.
9. Press the **GROSS** key to return to the Gross weighing mode.

INPUTS (Inputs Test)

INPUT.1 = XM64

SPEED = Speed Sensor Input

Use this item to test the Inputs

1. From **VOLTS**, press **MENU**. . .
LCD is displayed.
2. Press **MENU** repeatedly until. . .
INPUTS is shown.
3. Press the **SELECT** key and . . .
IN.1 is displayed.
4. Press the **SELECT** key and. . .
OPEN or **CLOSED** is displayed
5. Press the **SELECT** key. . .
IN.1 is displayed
6. Press the **MENU** key, and. . .
IN.2 is displayed
7. Press the **SELECT** key. . .
OPEN or **CLOSED** is displayed.
8. Press the **SELECT** key. . .
IN.2 is displayed
9. Repeat steps 6-8 until all inputs are checked.
10. Press the **GROSS** key to return to the Gross weighing mode.

RELAY (Alarm Light Test)

Use this test to check the Alarm light function.

1. From **VOLTS**, press **MENU**. . .
LCD is displayed.
2. Press **MENU** repeatedly until. . .
RELAY is shown.
3. Press the **SELECT** key and . . .
ON/OFF is displayed. While this is selected on the display, the alarm light relay will flash at 2/sec.
4. Press the **SELECT** key and . . .
RELAY is displayed.
5. Press the **GROSS** key to return to the Gross weighing mode.

SOFT **(Software Version)**

Use this menu item to see the software information stored in the 2040.

1. From **VOLTS**, press **MENU**. . .
LCD is displayed.
2. Press **MENU** repeatedly until. . .
SOFT is shown.
3. Press **SELECT** and. . .
PART: is displayed.
4. Press **MENU** and. . .
60125- is displayed
5. Press **MENU** and. . .
DASH: is displayed.
6. Press **MENU** and. . .
0012 is shown
7. Press **MENU** and. . .
REV: is shown
8. Press **MENU** and. . .
Current revision date is shown
9. Press **MENU** and. . .
bas.VER is shown
10. Press **MENU** and. . .
16814 is displayed
11. Press **MENU** and. . .
bas.REV is shown
12. Press **MENU** and. . .
Current revision is shown
13. Press **MENU** and. . .
SOFT is displayed
14. Press the **GROSS** key to return to the Gross weighing mode.

Setting Factory Defaults

Accessing this menu will set all parameters to factory defaults.

It is very important that you do this only if you are sure. All entered information is lost and there is no way to retrieve it.

1. From the Gross Mode, press and hold on the **MENU** key for three beeps (3 seconds), then release. . .
SET.PAS is displayed.
2. Use the keypad, enter '222174'. . .
********* is displayed
3. Then press the **SELECT** key. . .
DFAULT is displayed
4. The unit returns to the Gross weighing mode.

Production Or Service Factory Calibration

Accessing this menu gives production or service access to calibrating factory calibration as follows: (1 mv/v = 10000 lb)

Accessing Factory Calibration Mode

1. From the Gross Mode, press and hold on the **MENU** key for three beeps (3 seconds), then release. . .
SET.PAS is displayed.
2. Use the keypad, enter '010101'. . .
********* is displayed
3. Then press the **SELECT** key. . .
ZERO is displayed

Setting Zero Calibration

1. From **ZERO**, press **SELECT**. . .
SET.0MV is displayed.
2. Dial calibrator to 0 mV/V, press **SELECT**. . .
DET.ZER then **DONE** is displayed.
3. Returns to the **ZERO** display
4. Press the **GROSS** key to return to the Gross weighing mode.

Setting the Span Calibration

1. From **ZERO**, press **MENU**. . .
SPAN is displayed.
2. Press **SELECT** and. . .
SET1MV is displayed.
3. Dial calibrator to 1 mV/V, press **SELECT**. . .
DET.SPN then **DONE** is displayed
4. Returns to the **SPAN** display.
5. Press the **GROSS** key to return to the Gross weighing mode.

Viewing Current Calibration

1. From **ZERO**, press **MENU** repeatedly until. . .
DISP is displayed.
2. Press **SELECT** and. . .
Current weight calibration is displayed
3. Press **SELECT**. . .
DISP is displayed.
4. Press the **GROSS** key to return to the Gross weighing mode.

Viewing Factory Span Factor

1. From **ZERO**, press **MENU** repeatedly until. . .
VIEW is displayed
2. Press **SELECT** and. . .
Current span factor is displayed. 1 mv/v = 100000 if electronics are all exact. For example if off 0.01%, could read 99990
3. Press **SELECT**. . .
VIEW is displayed
4. Press **GROSS** key . . .
To return to the Gross weighing mode

Re-setting Factory Span Without Calibrating with a Simulator

Use this to return the unit to its factory calibration. You need to first retrieve the factory span value from the indicator, clear memory and re-enter the value at this point.

1. From **ZERO**, press **MENU** repeatedly until. . .
SET is displayed.
2. Press **SELECT** and. . .
FAC.SPN is displayed.
3. Enter factory span value. . .
Entered value is displayed.
4. Press **SELECT** and. . .
SET is displayed
5. Press the **GROSS** key to return to the Gross weighing mode.

MODEL 2040 INDICATOR
(This Page Intentionally Blank)

MODEL 2040 INDICATOR PARTS AND ASSEMBLY

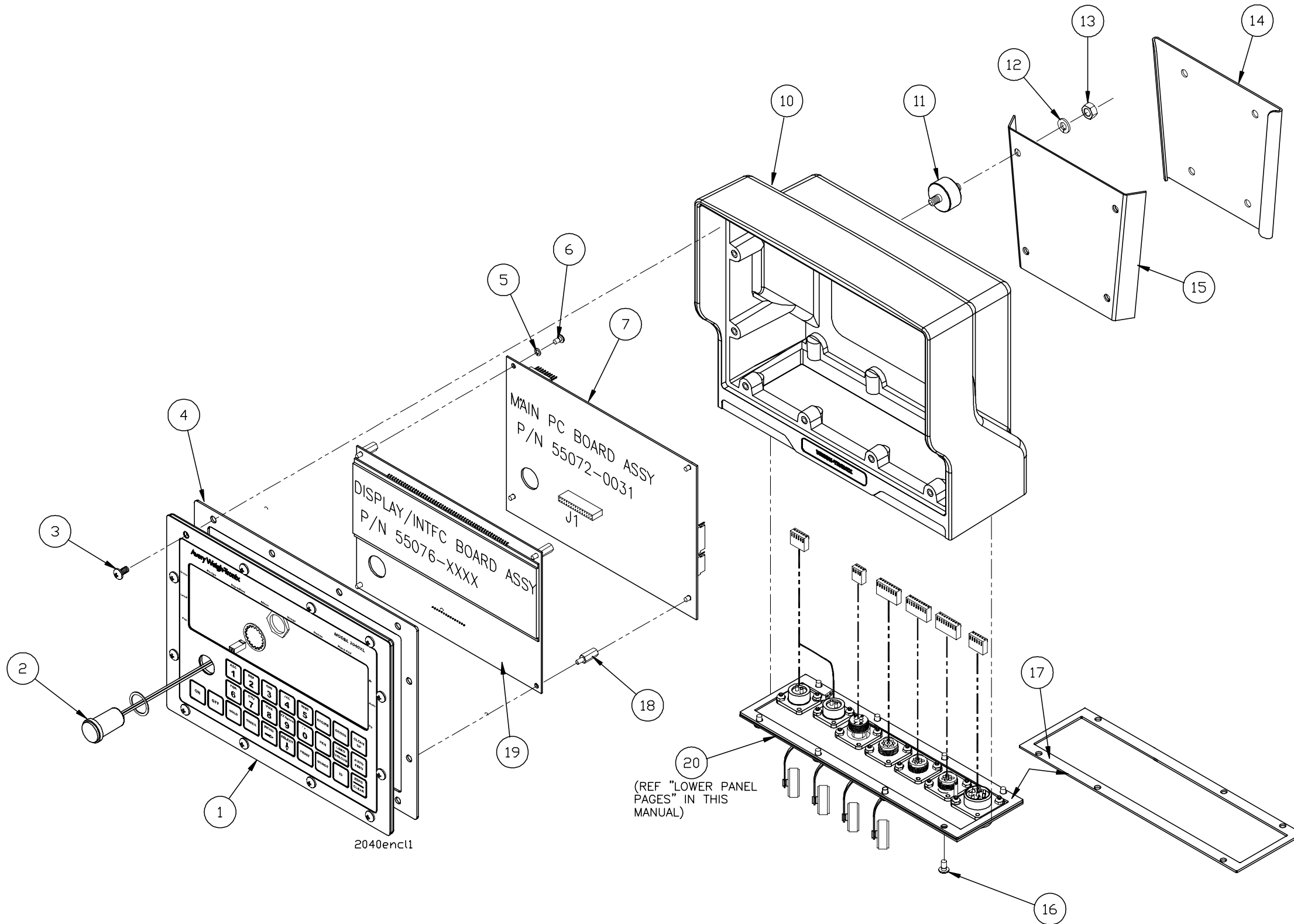

ITEM NO.	DESCRIPTION	W-T P/N	QTY
1	Keypad/Backer Plate Assy, (includes gasket)	55087-0083	1
2	Alarm Light Assy	24129-0014	1
3	Screw, #10-32 x .38"L	14503-8030	12
4	Replacement Gasket, sticky one side, (for item 1)	47694-0010	1
5	Lock Washer, #6	14474-0032	4
6	Screw, #6-32 x .25"L	14473-0223	4
7	Main Pc Bd Assy	55072-0031	1
8	--NOPART--	-----	---
9	--NOPART--	-----	---
10	Enclosure	47017-0010	1
11	Rubber Vibration Mount (incl. w/ Indicator)	17807-0108	4
12	Lock Washer, .25" (incl. w/ Indicator)	14474-0198	4
13	Hex Nut, .25-20 (incl. w/ Indicator)	14471-0209	4
14	Mtg. Bracket (optional)	12339-0015	1
15	Mtg. Bracket (included w/ Indicator)	11899-0043	1
16	Screw, #8-32 x .31"L	14473-0348	8
17	Replacement Gasket, sticky one side(for item 20)	47695-0019	1
18	Standoff, hex, #6-32 x .50"L, M/F	15437-0449	4
19	Display/Interface XL Board Assy (large display)	55076-0011	1
	Display/Interface Board Assy (std. display)	55076-0029	1
20	Lower Panel Assembly options : <i>(ref. lower pnl. option pages in this manual)</i>		
	W-T 7-pin j-box interface (<i>basic version</i>)	55373-0144svc	1
	W-T 7-pin j-box interface (<i>basic version, plus Revolution Count input & Com-2</i>)	55373-0169svc	1
	Amp. 4-pin j-Box interface (<i>basic version</i>)	55373-0151svc	1
	Amp. 4-pin j-Box interface (<i>basic version, plus Revolution Count input & Com-2</i>)	55373-0177svc	1
	5-pin (full bridge) 3-weigh bar (w/o j-box intfc.)	55374-0085svc	1
	5-pin (full bridge) 4-weigh bar (w/o j-box intfc.)	55374-0077svc	1
	4-pin (quarter bridge) 4-weigh bar (w/o j-box intfc.)	55374-0093svc	1

MODEL 2040 INDICATOR
OUTLINE DRAWING

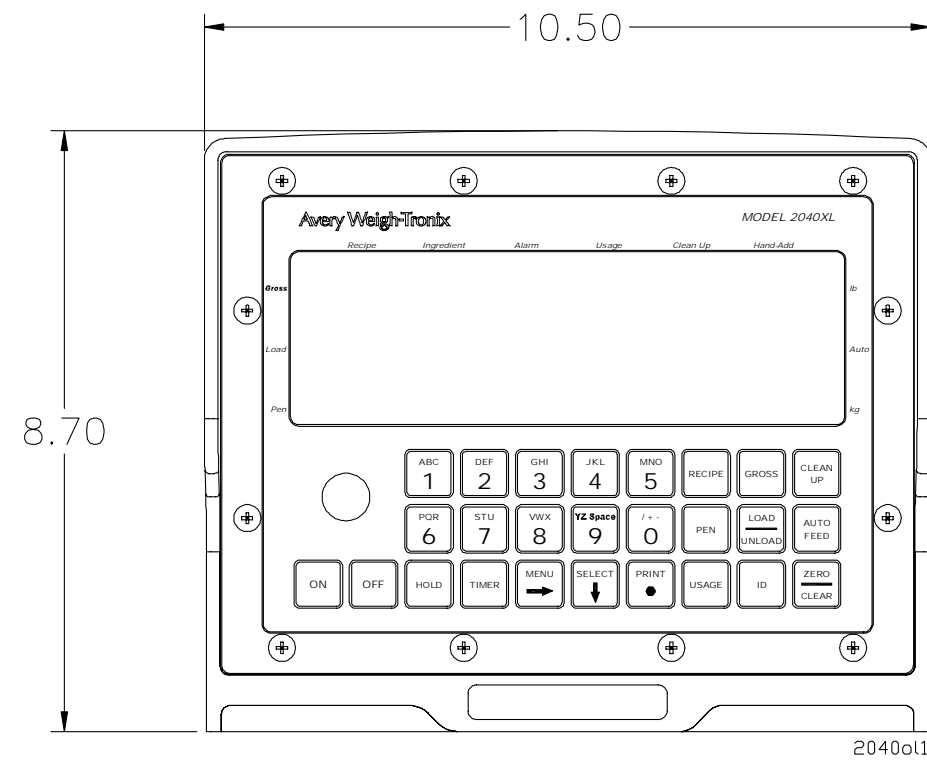

(FRONT VIEW)

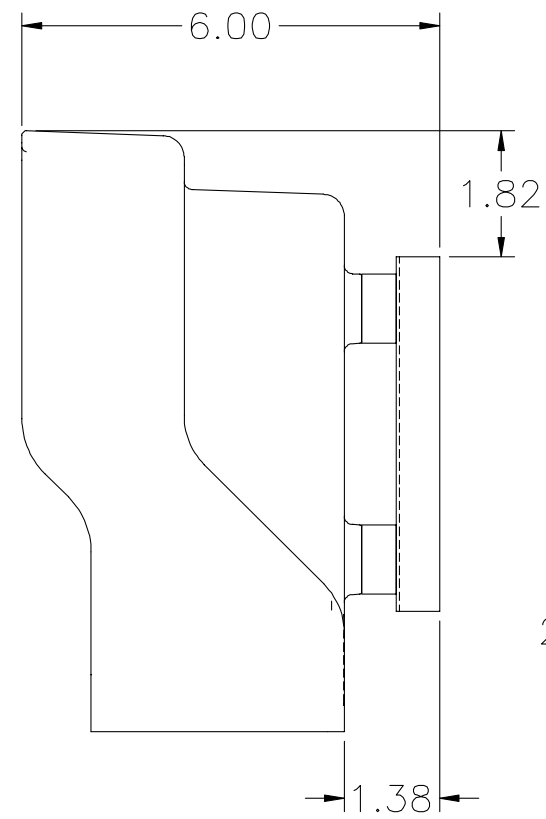

(SIDE VIEW)

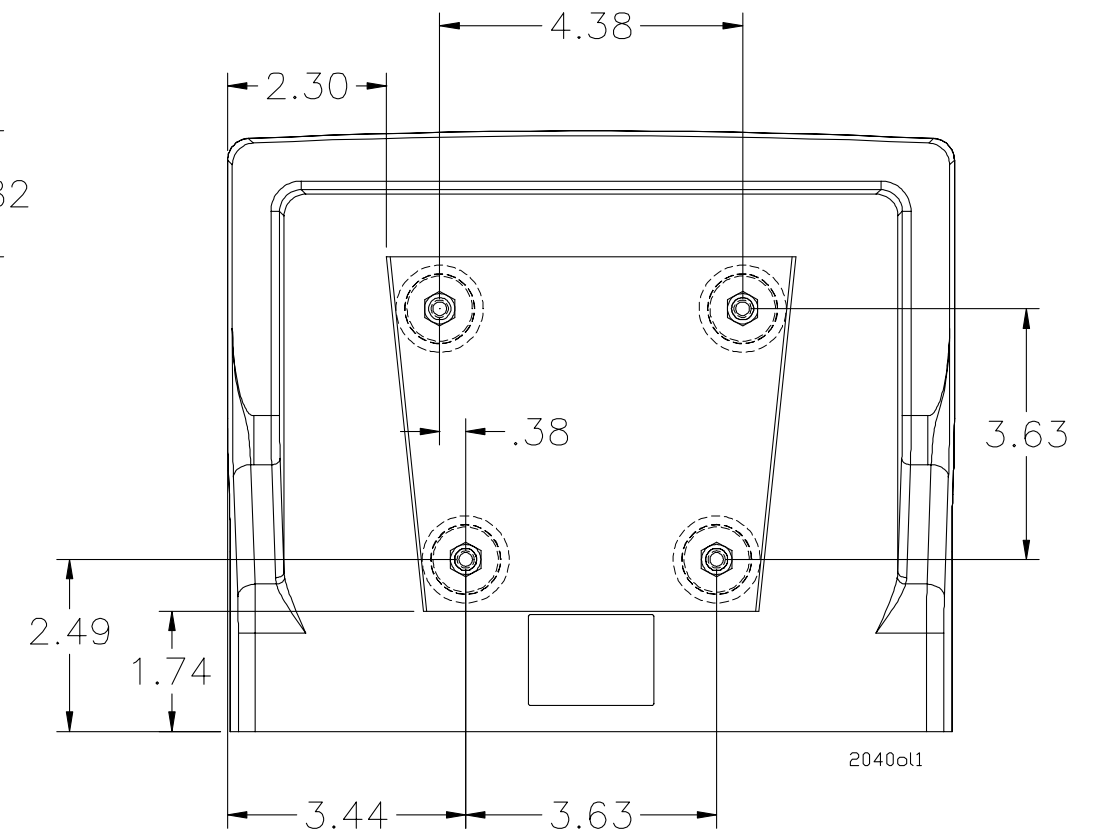

(REAR VIEW)

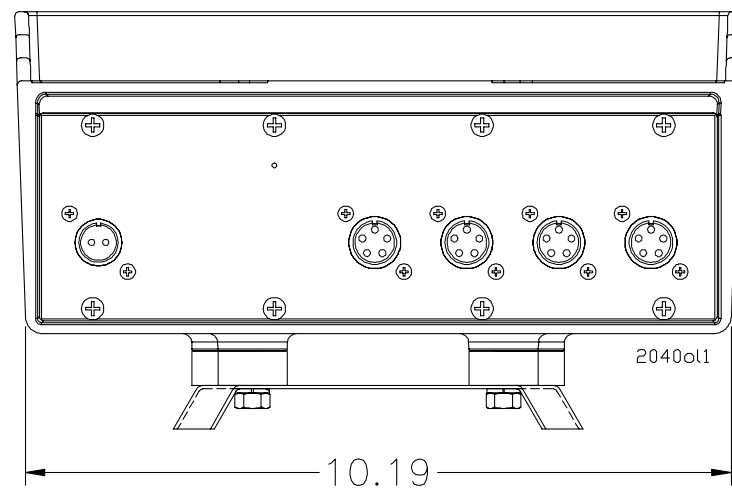

(BOTTOM VIEW)

**MODEL 2040 INDICATOR
SYSTEM DIAGRAM**

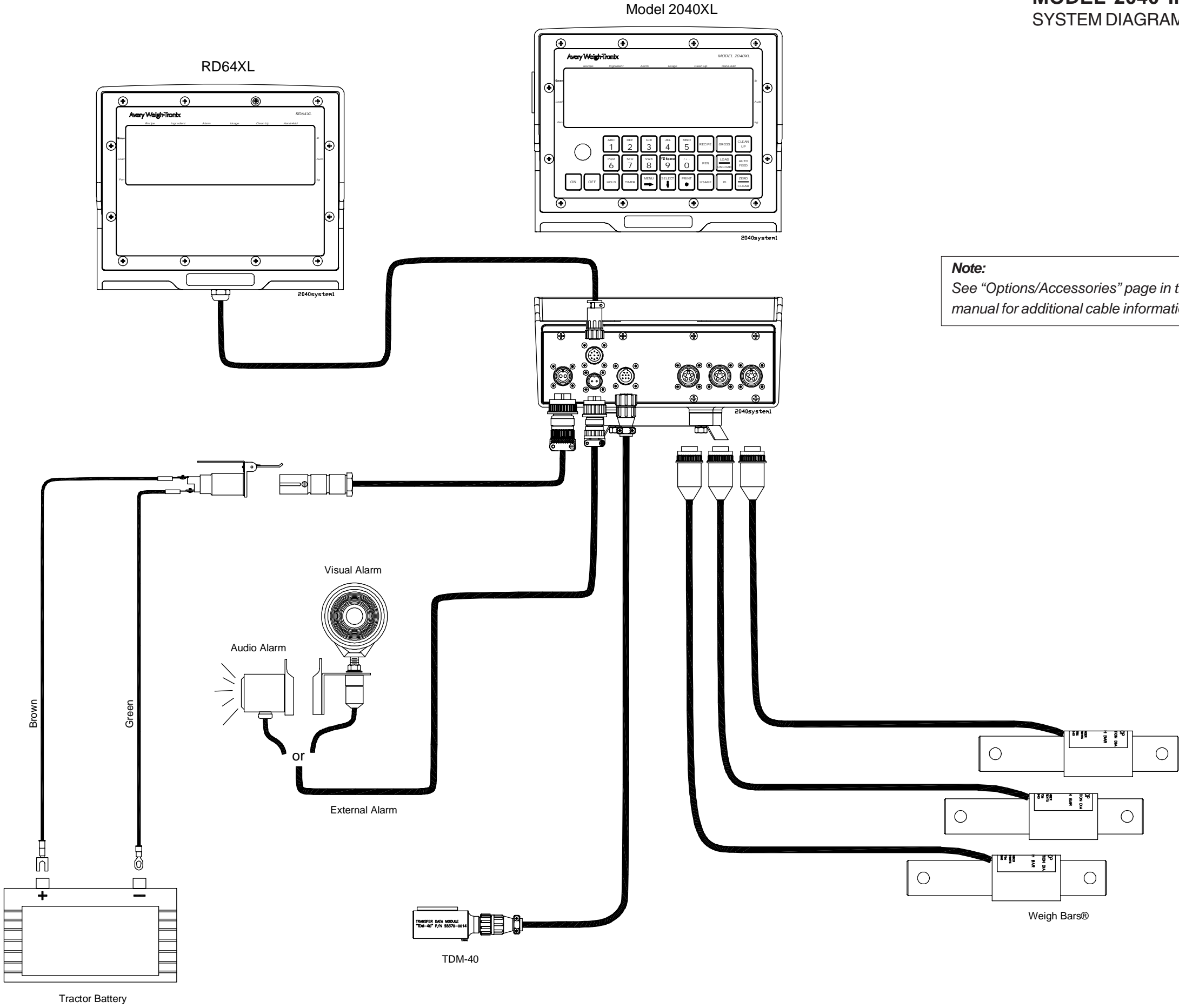

Note:
See "Options/Accessories" page in this manual for additional cable information.

MODEL 2040 INDICATOR SYSTEM BLOCK DIAGRAM

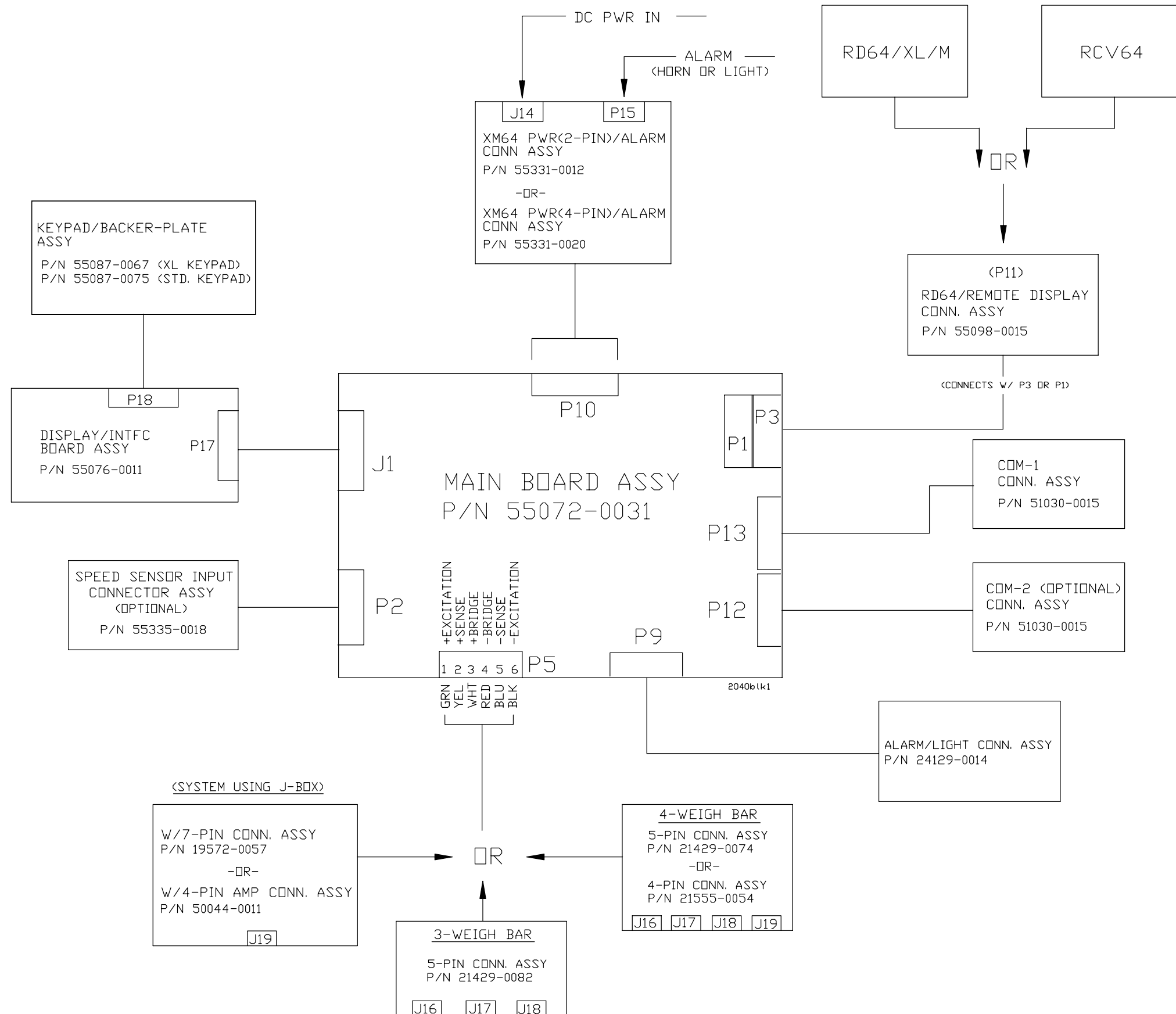

MODEL 2040 INDICATOR
 KEYPAD/BACKER PLATE ASSY
 P/N 55087-0067 (XL KEYPAD)
 P/N 55087-0075 (STD. KEYPAD)
 & SCHEMATIC

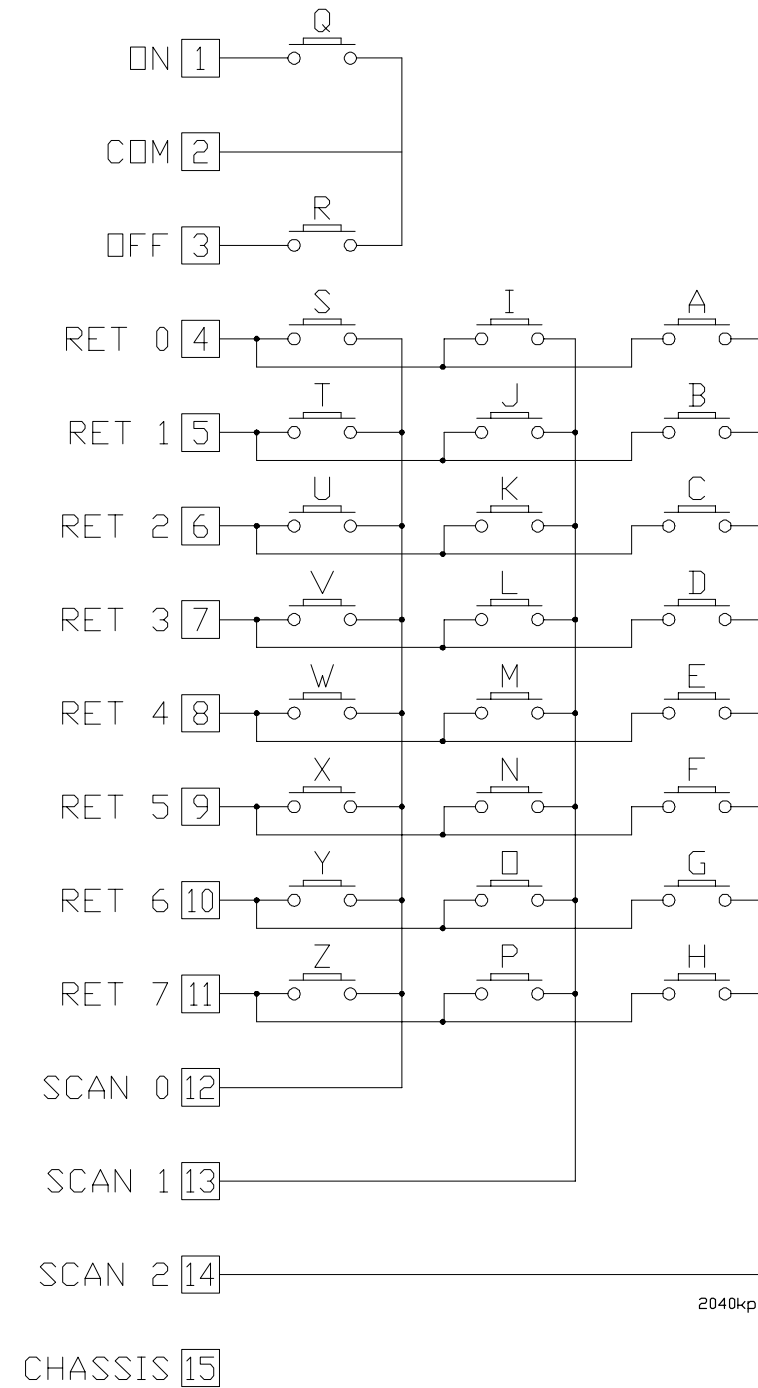
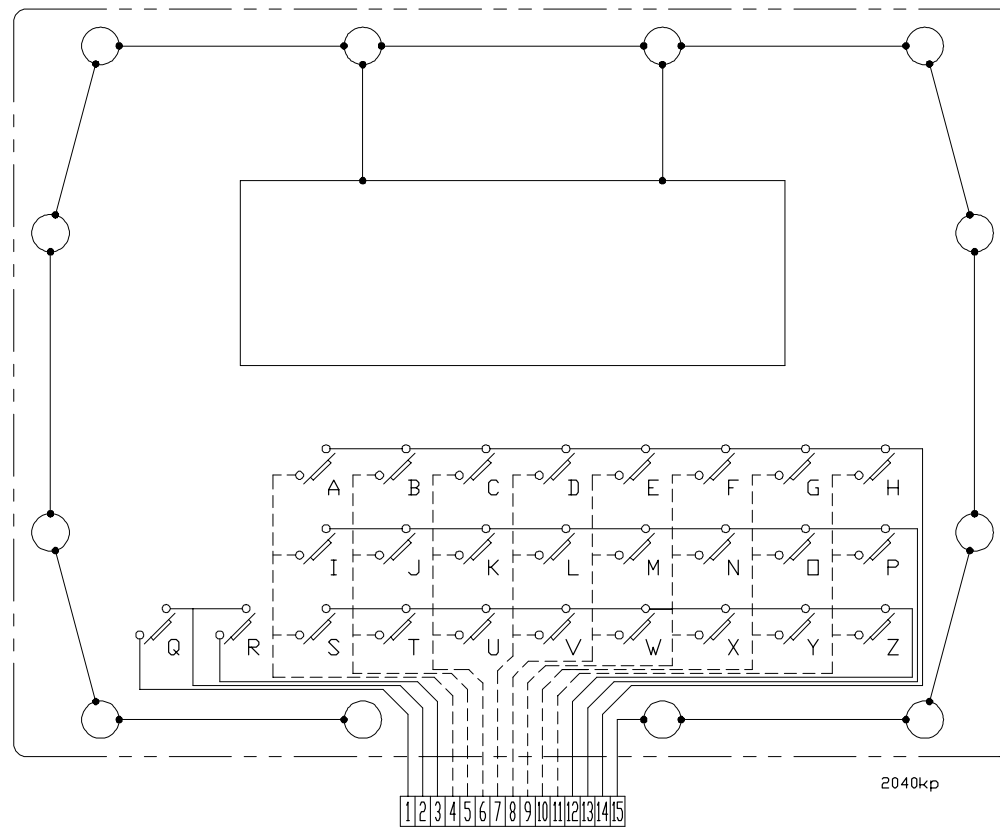
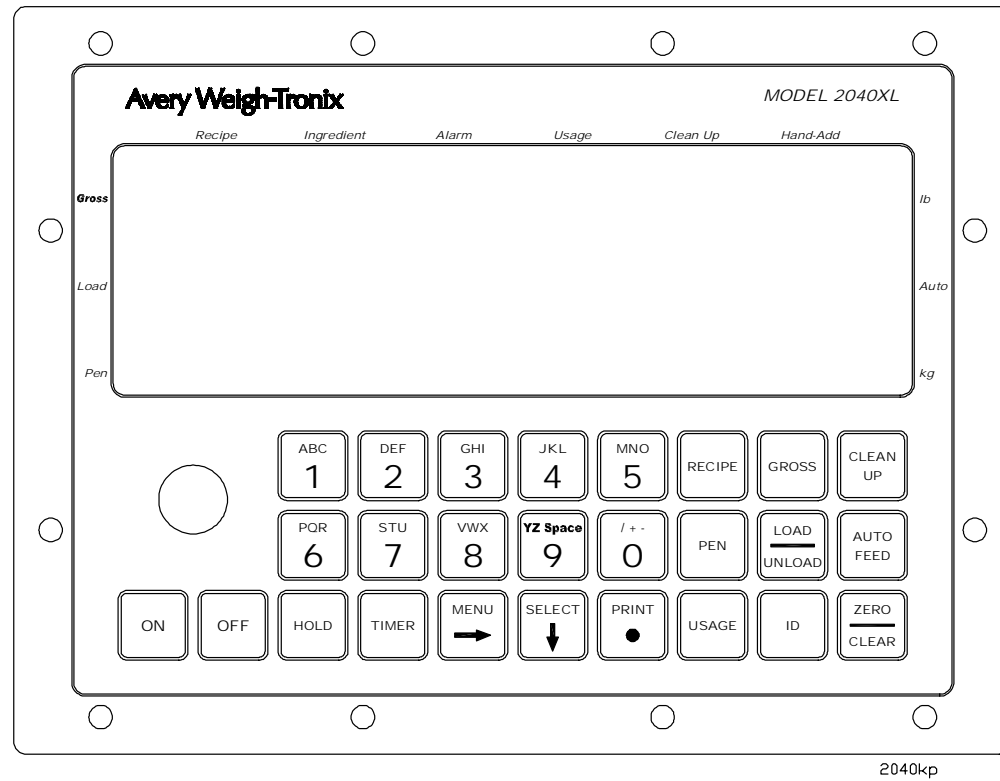

SCHEMATIC DIAGRAM

MODEL 2040 INDICATOR
DISPLAY/INTERFACE BOARD ASSY
 55076 -0011 (XL)
 55076-0029 (STD)

2040XL DISPLAY BOARD
 P/N 55076-0011 (large display)

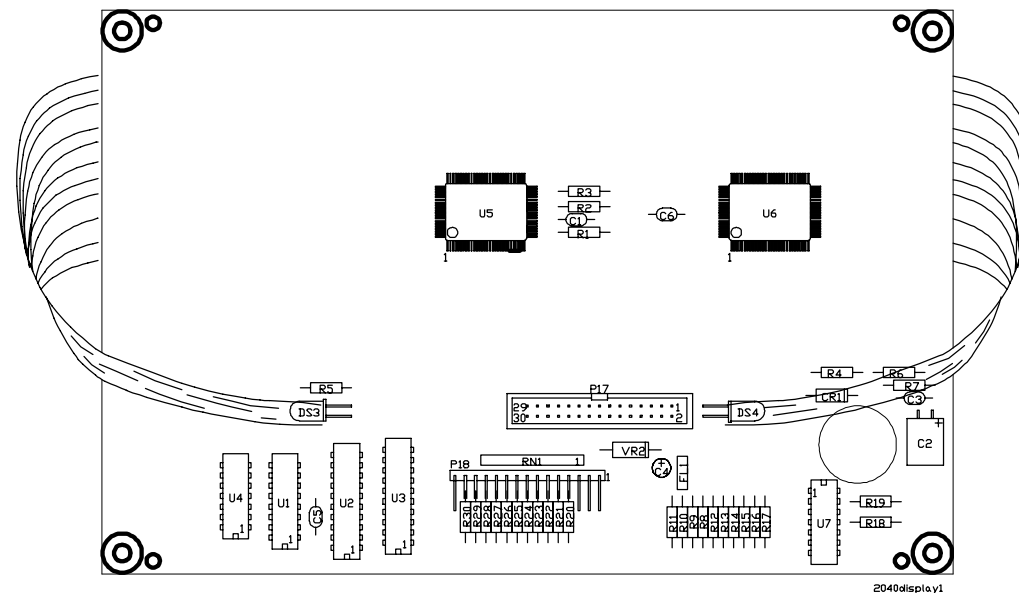

COMPONENT SIDE

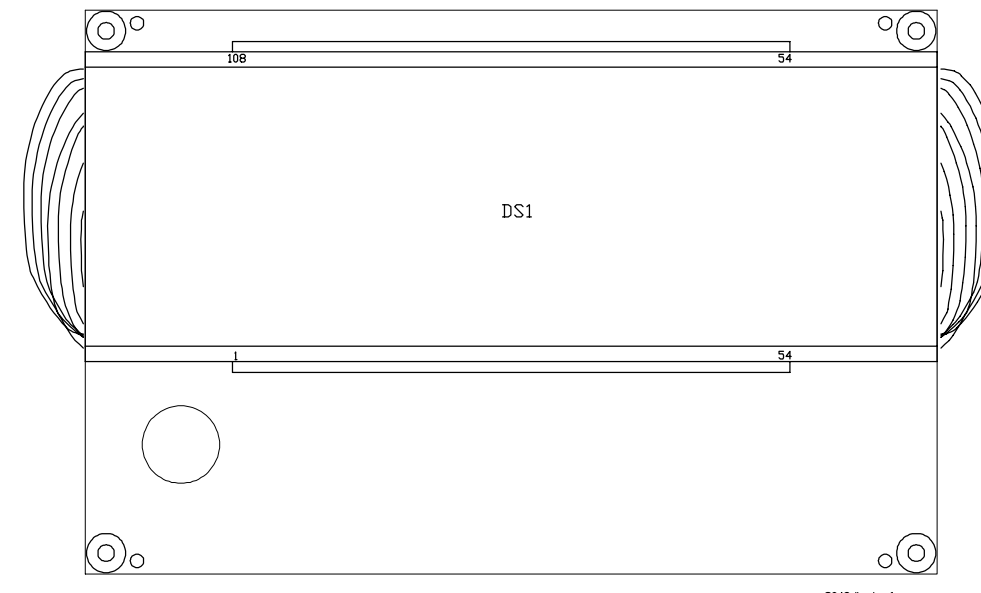

DISPLAY SIDE

2040 DISPLAY BOARD
 P/N 55076-0029 (std. display)

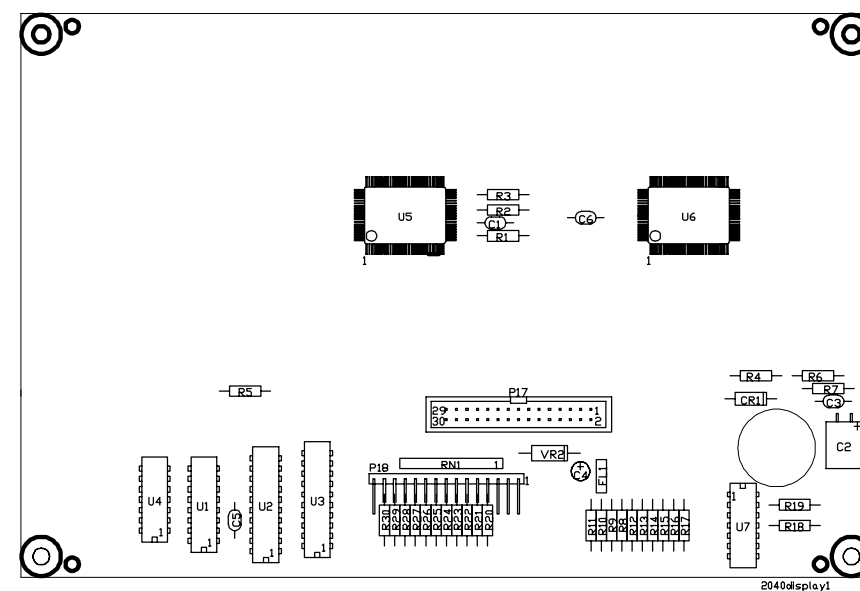

COMPONENT SIDE

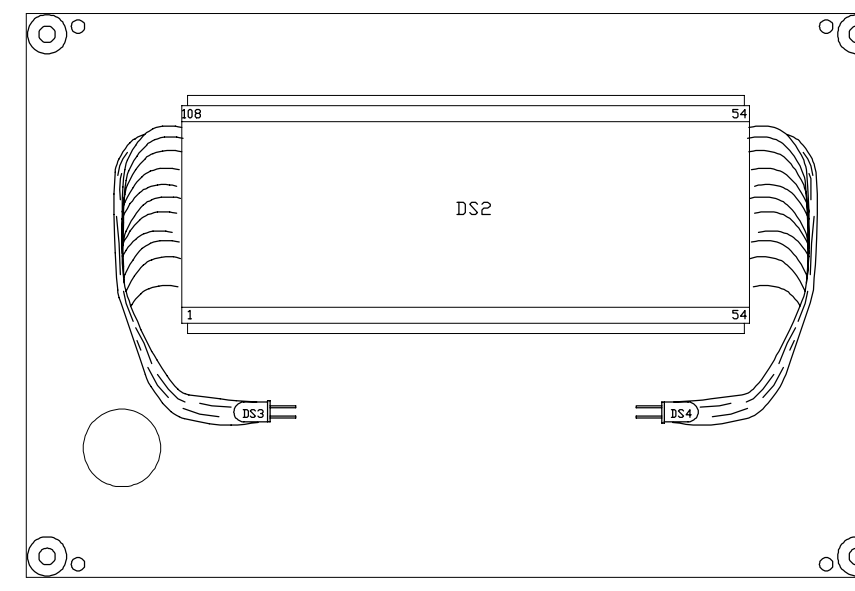

DISPLAY SIDE

MODEL 2040 INDICATOR
MAIN PC BOARD
P/N 55072-0031

CAUTION !

DANGER OF EXPLOSION IF BATTERY IS INCORRECTLY REPLACED.

REPLACE BATTERY (B1) ONLY WITH THE SAME OR EQUIVALENT TYPE RECOMMENDED BY THE MANUFACTURER.

DISPOSE OF USED BATTERIES ACCORDING TO THE MANUFACTURER'S INSTRUCTIONS.

NOTE:
 WHEN USING RD64 or RCV-64 WITH AN XMT/RCVR SET, INSTALL JUMPER ON P14, PINS 1-2.

RD64 REMOTE DISPLAY (P1 OR P3)

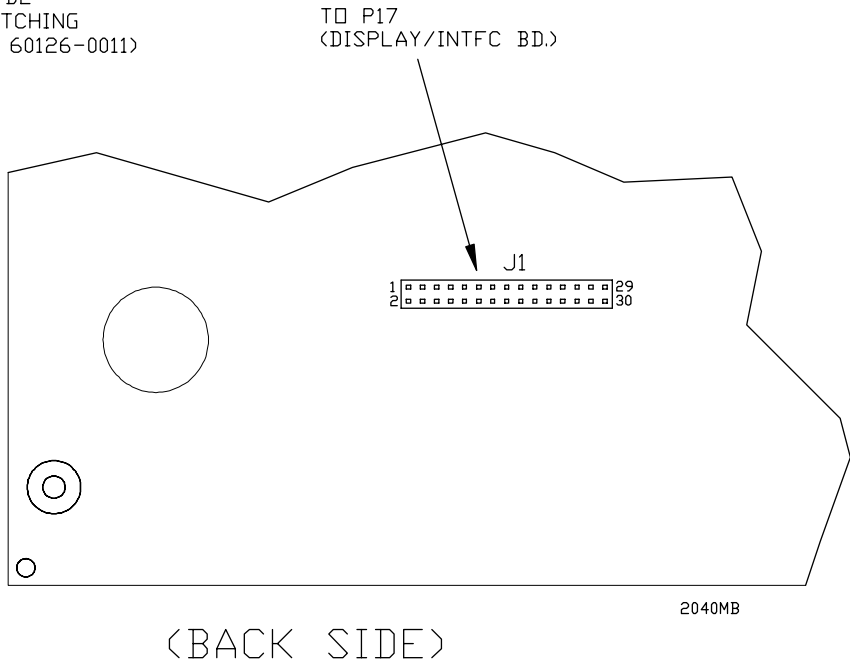
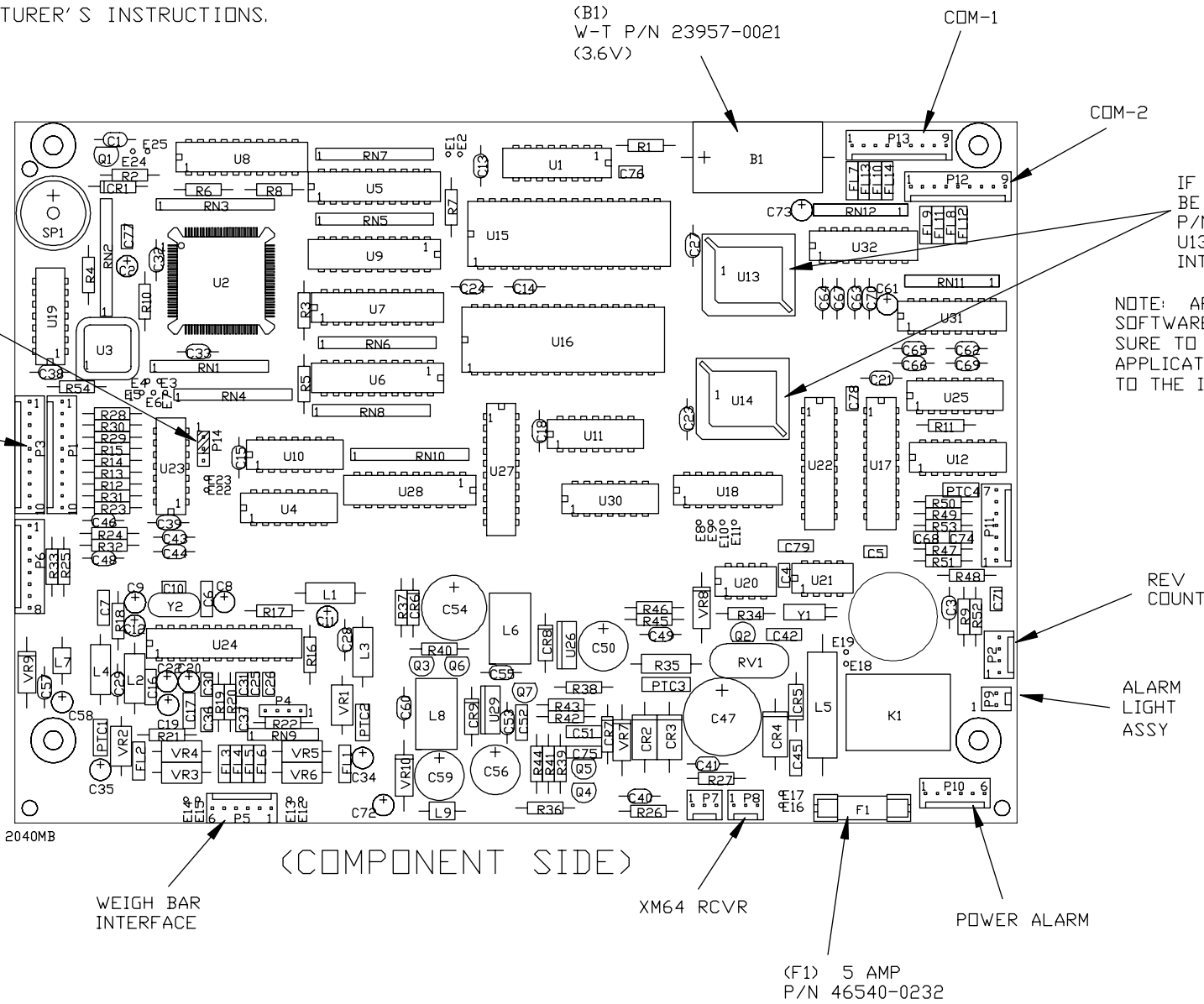

MODEL 2040 INDICATOR
LOWER PANEL OPTIONS
(FOR SYSTEMS USING J-BOX)

Complete Panel Assembly as shown: p/n 55373-0144

(Ref: "Pin-Out" Pages in this Manual)

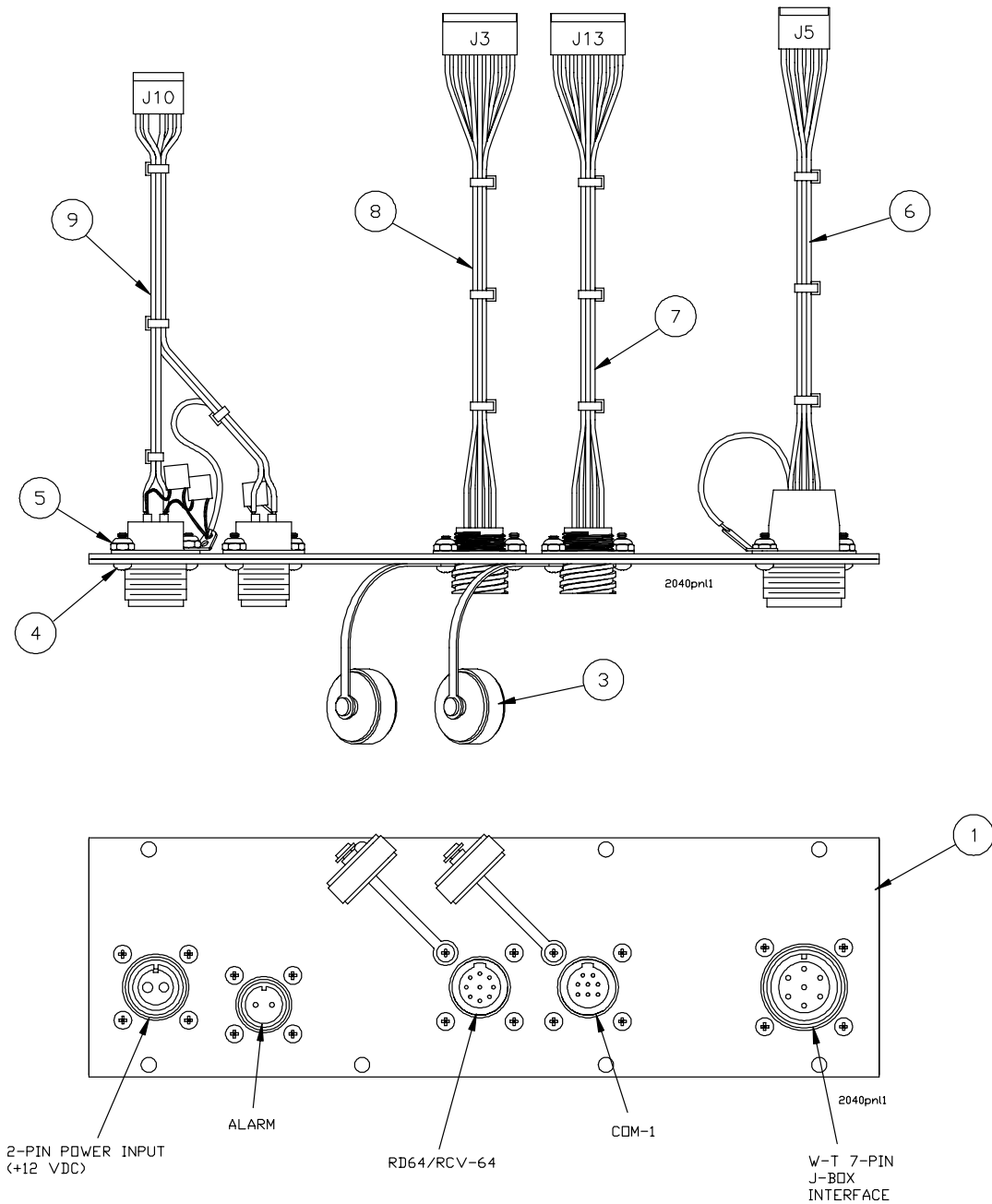

ITEM NO.	DESCRIPTION	W-T P/N	QTY
1	Bottom Plate (std.), stainless	55091-0020	1
2	Bottom Plate (w/ options), stainless	55091-0046	1
3	Cover Cap w/ strap	48684-0010	4(max)
4	Screw, #4-40 x .38"L	14473-0124	28(max)
5	Lock Nut, #4-40	14464-0026	28(max)
6	Weigh Bar Cable Assy (7-pin)	19572-0123	1
7	Cable Assy, RS232 (Com-1)	51030-0023	1
	Cable Assy, RS232 (Com-2) (optional)	51030-0023	1
8	Cable Assy, RD64 (remote display)	55098-0023	1
9	Cable Assy, 2-pin Pwr/Alarm	55331-0012	1
10	Cable Assy, Speed Sensor (optional)	55335-0018	1

Complete Panel Assembly as shown: p/n 55373-0169

(Ref: "Pin-Out" Pages in this Manual)

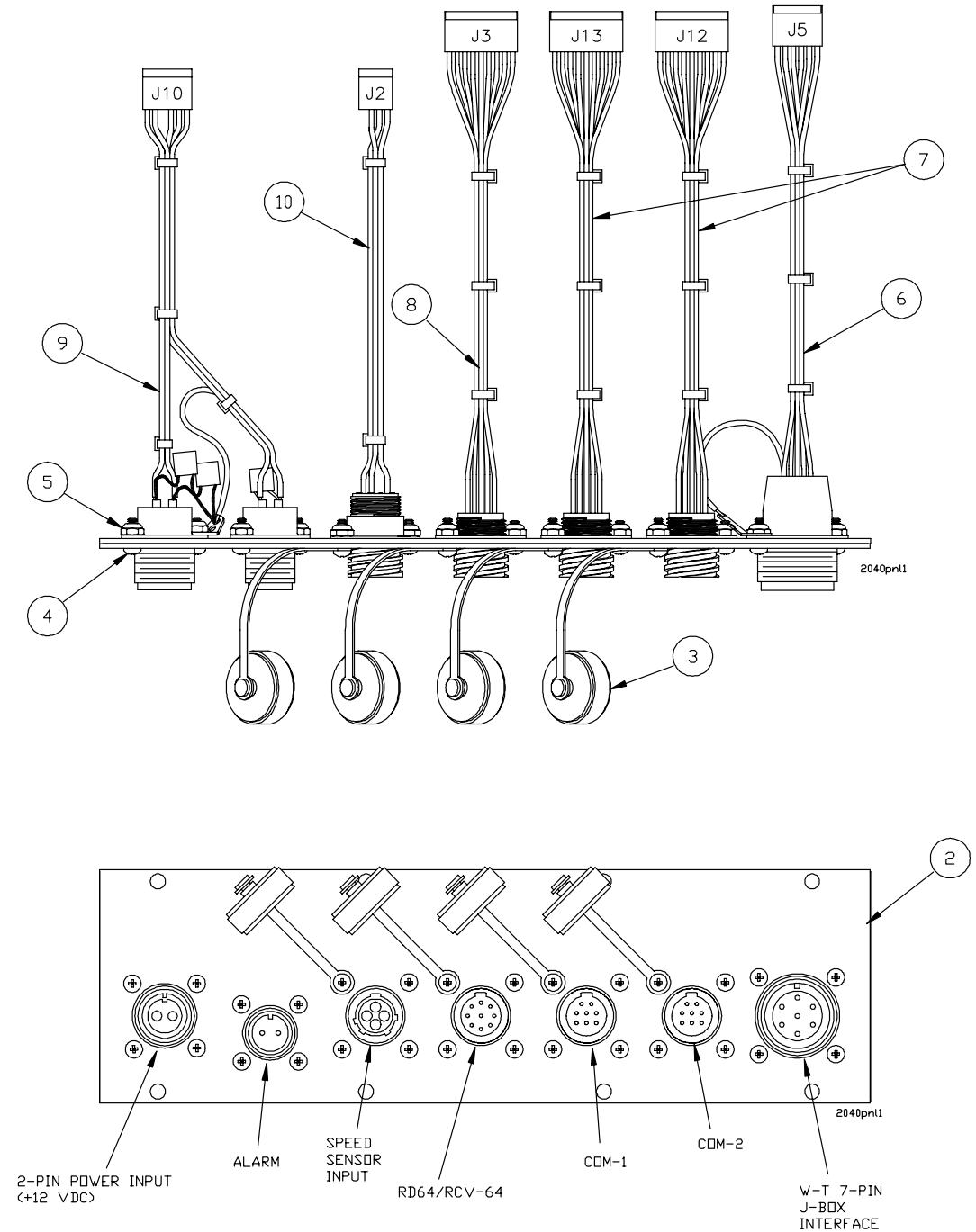

MODEL 2040 INDICATOR
LOWER PANEL OPTIONS
(FOR SYSTEMS USING J-BOX)

Complete Panel Assembly as shown: p/n 55373-0151

(Ref: "Pin-Out" Pages in this Manual)

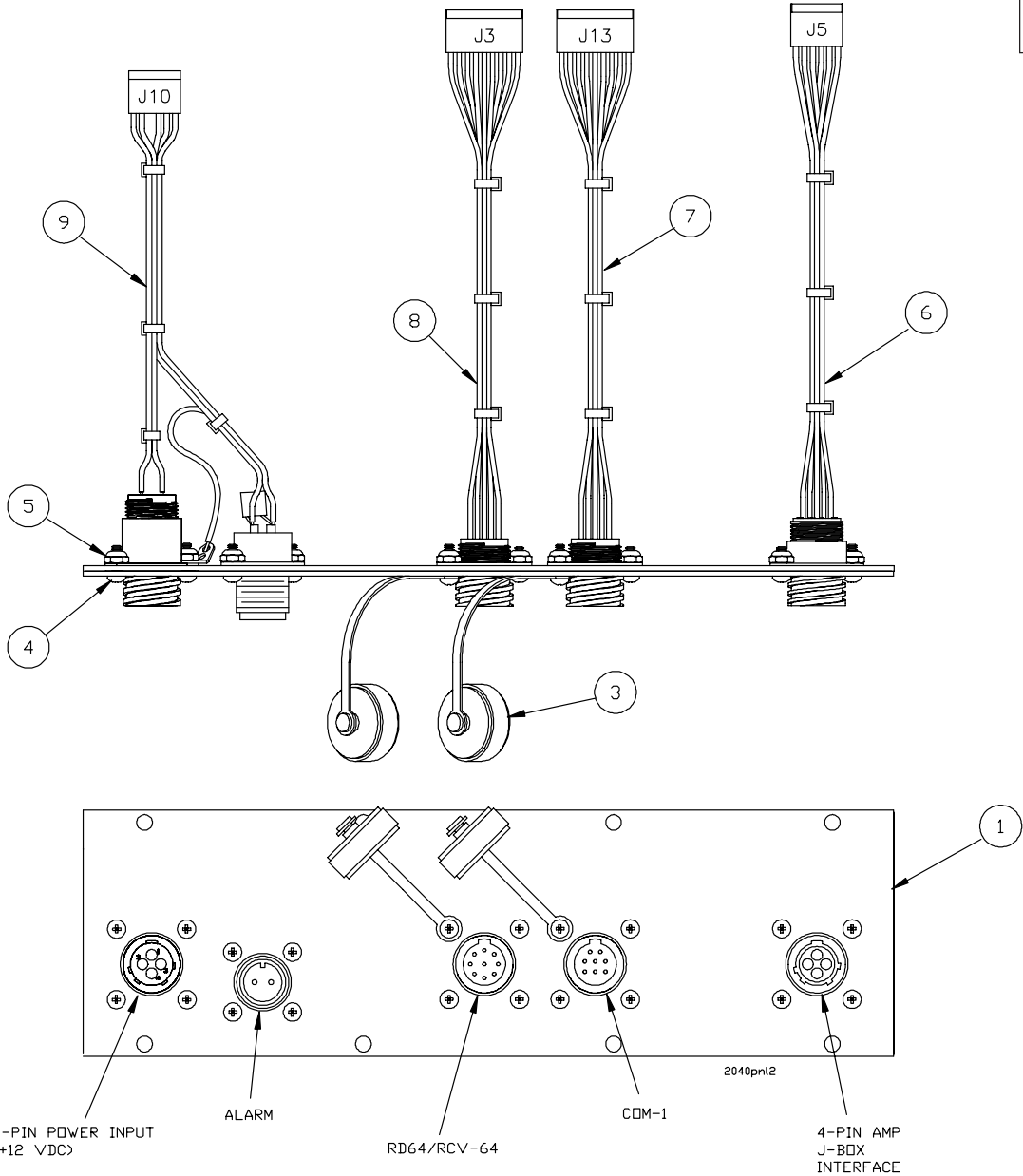

ITEM NO.	DESCRIPTION	W-T P/N	QTY
1	Bottom Plate (<i>std.</i>), stainless	55091-0038	1
2	Bottom Plate (<i>w/ options</i>), stainless	55091-0053	1
3	Cover Cap w/ strap	48684-0010	4(max)
4	Screw, #4-40 x .38"L	14473-0124	28(max)
5	Lock Nut, #4-40	14464-0026	28(max)
6	Weigh Bar Conn. Cable Assy (4-pin Amp.)	50044-0029	1
7	Cable Assy, RS232 (Com-1)	51030-0023	1
	Cable Assy, RS232 (Com-2) (<i>optional</i>)	51030-0023	1
8	Cable Assy, RD64 (remote display)	55098-0023	1
9	Cable Assy, 4-pin Pwr/2-pin Alarm	55331-0012	1
10	Cable Assy, Speed Sensor (<i>optional</i>)	55335-0018	1

Complete Panel Assembly as shown: p/n 55373-0177

(Ref: "Pin-Out" Pages in this Manual)

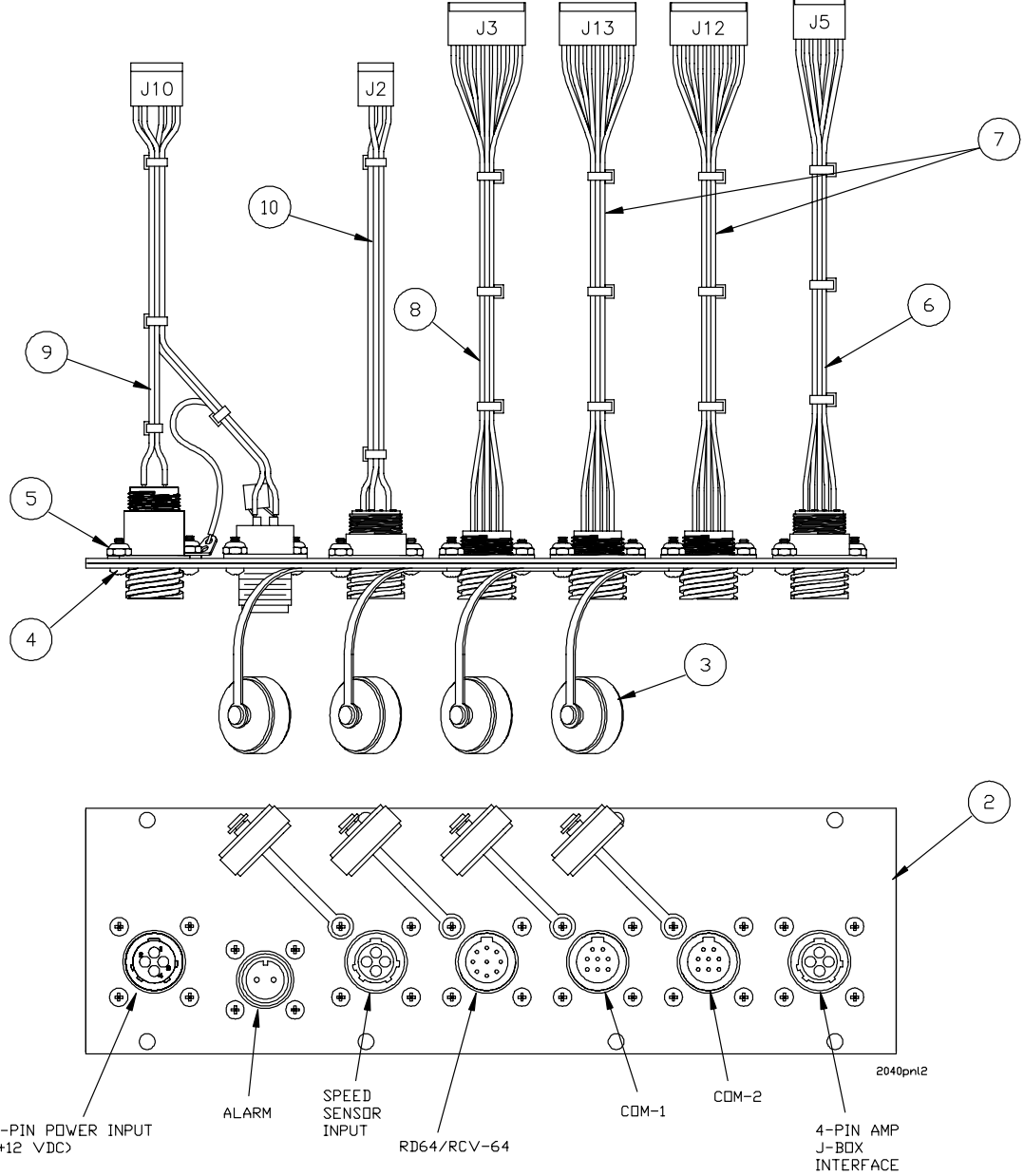

MODEL 2040 INDICATOR
 LOWER PANEL OPTIONS
 (FOR SYSTEMS W/O J-BOX)

Complete Panel Assembly as shown: p/n 55374-0085

(Ref: "Pin-Out" Pages in this Manual)

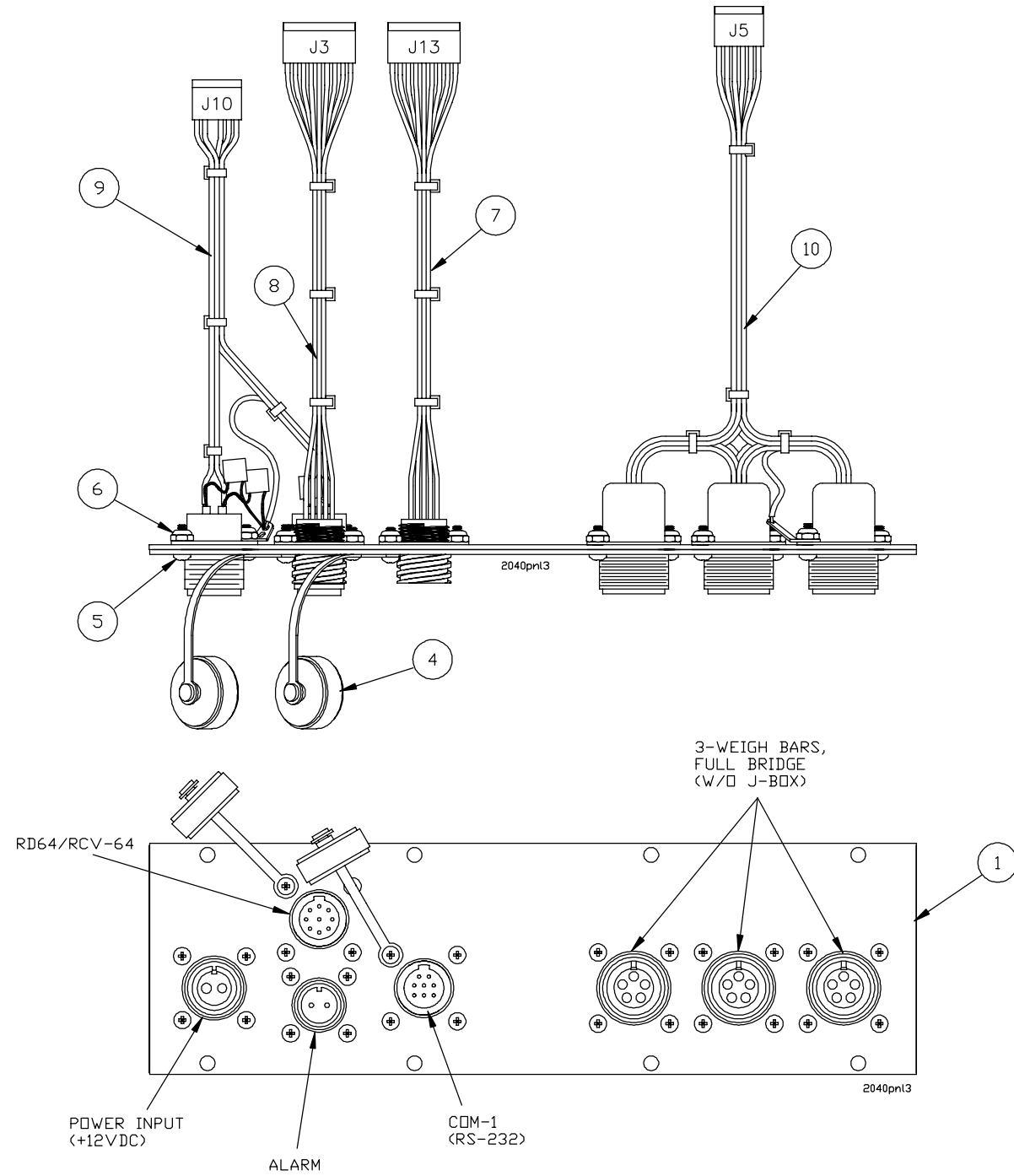

(Note: See "Parts List" next page)

Complete Panel Assembly as shown: p/n 55374-0077

(Ref: "Pin-Out" Pages in this Manual)

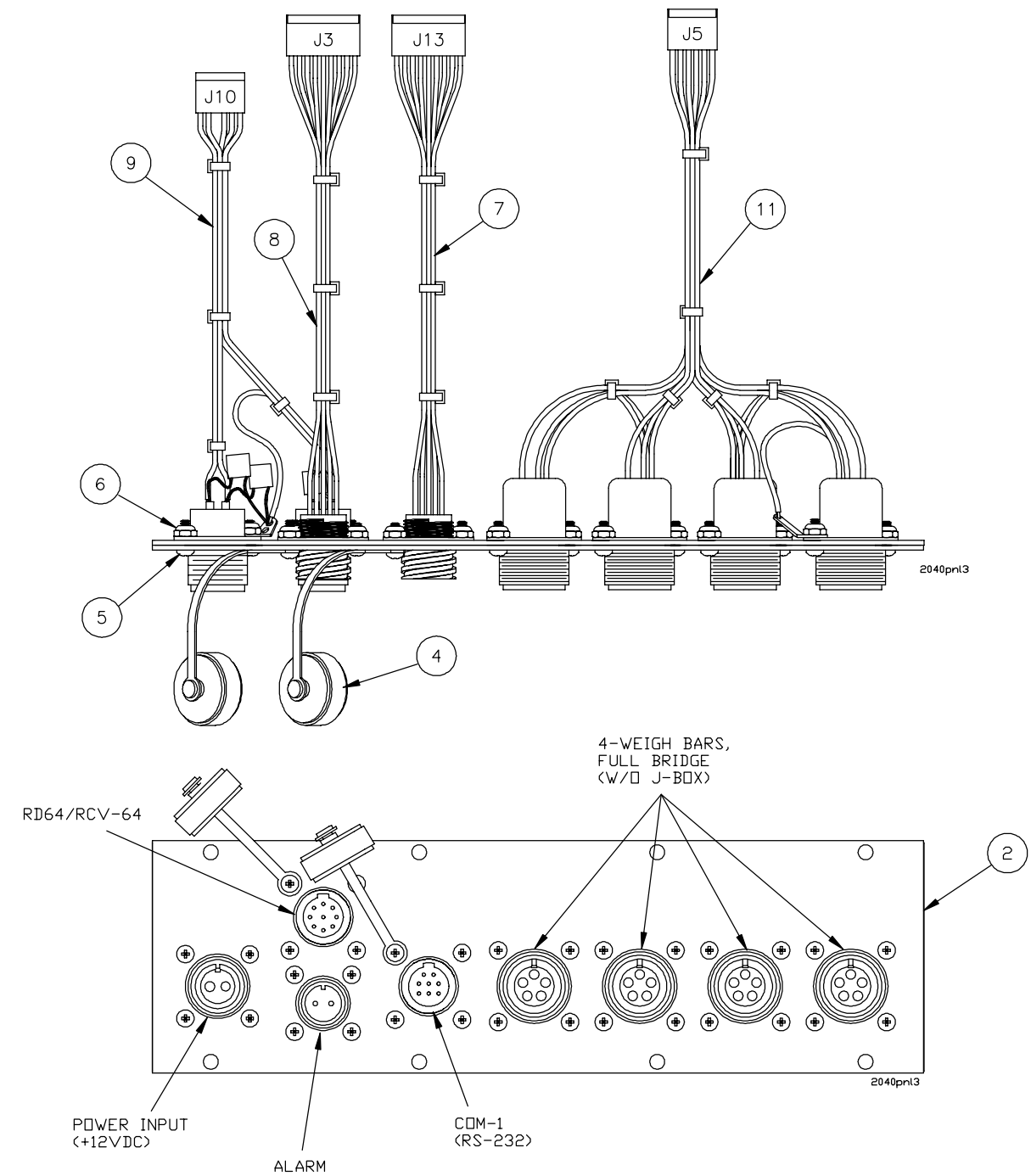

MODEL 2040 INDICATOR
LOWER PANEL OPTIONS
(FOR SYSTEMS W/O J-BOX)

Complete Panel Assembly as shown: p/n 55374-0093

(Ref: "Pin-Out" Pages in this Manual)

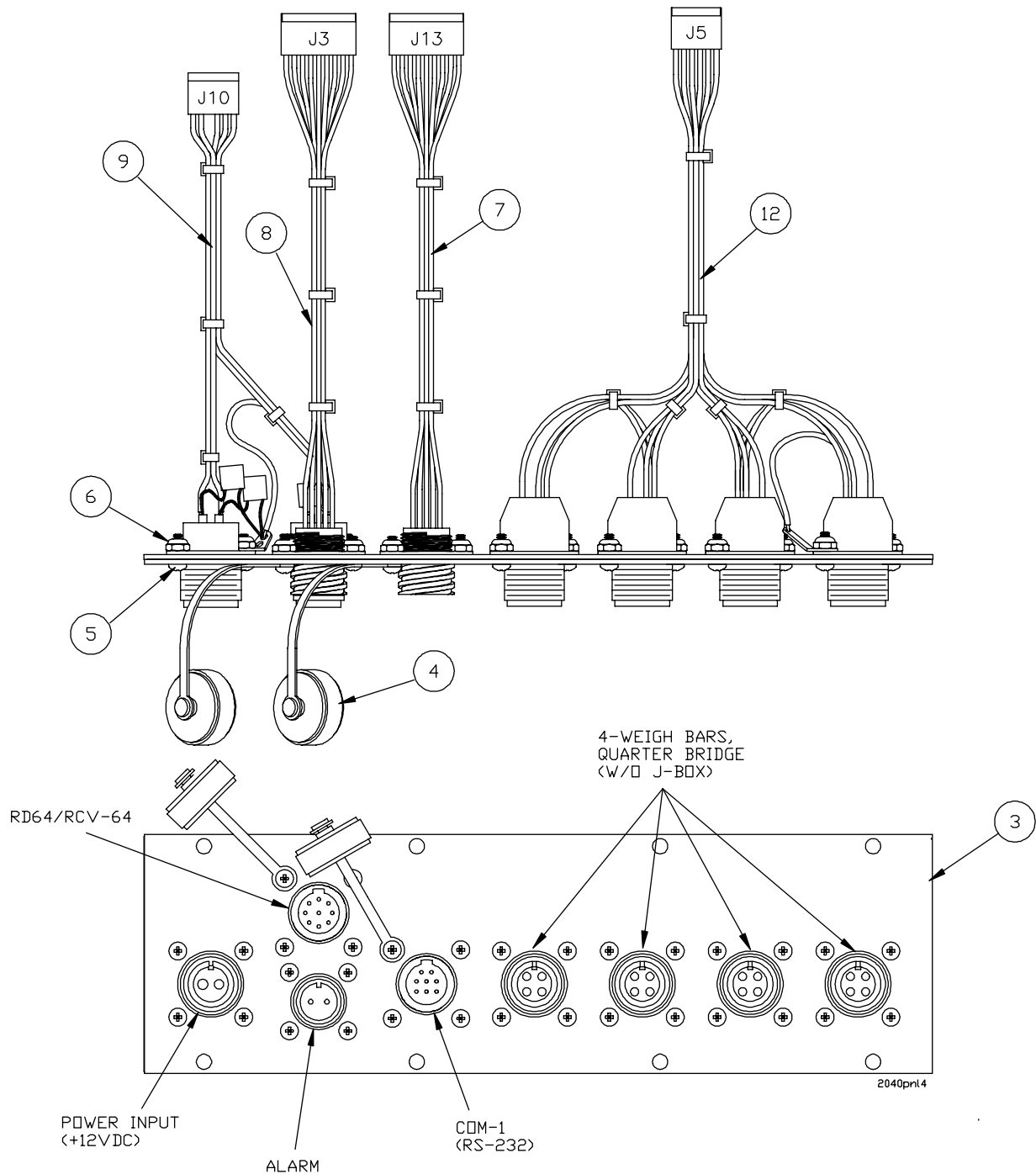

ITEM NO.	DESCRIPTION	W-T P/N	QTY
1	Bottom Plate (5-pin, 3-weighbars), stainless	55092-0029	1
2	Bottom Plate (5-pin, 4-weighbars), stainless	55092-0011	1
3	Bottom Plate (4-pin, 4-weighbars), stainless	55092-0037	1
4	Cover Cap w/ strap	48684-0010	2
5	Screw, #4-40 x .38"L	14473-0124	32(max)
6	Lock Nut, #4-40	14464-0026	32(max)
7	Cable Assy, RS232 (Com-1)	51030-0023	1
8	Cable Assy, RD64 (remote display)	55098-0023	1
9	Cable Assy, 2-pin Pwr/2-pin Alarm	55331-0012	1
10	Weigh Bar Conn. Assy (5-pin, 3-weigh bar)	21429-0108	1
11	Weigh Bar Conn. Assy (5-pin, 4-weigh bar)	21429-0116	1
12	Weigh Bar Conn. Assy (4-pin, 4-weigh bar)	21555-0054	1

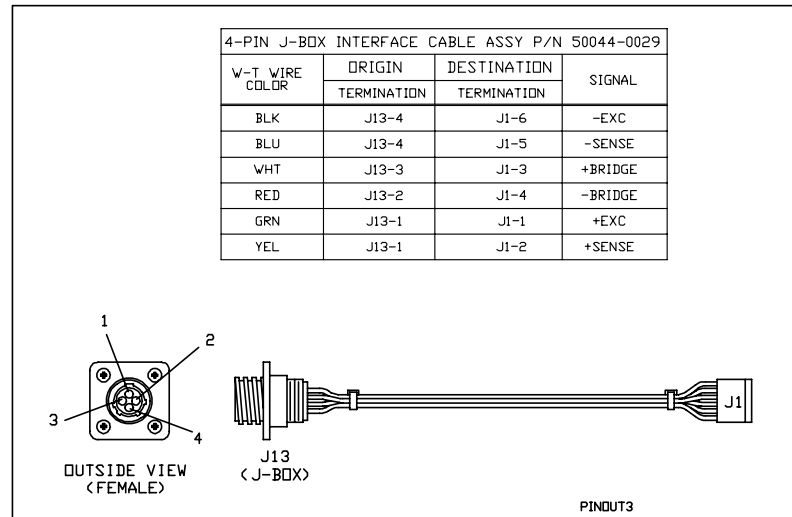
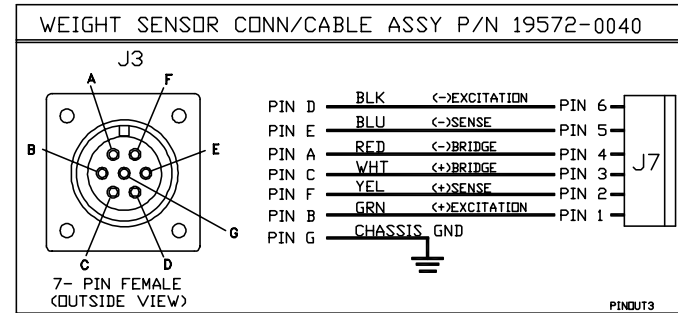

MODEL 2040 INDICATOR
"LOWER PANEL" CONNECTOR/CABLE ASSY
-PIN-OUTS-

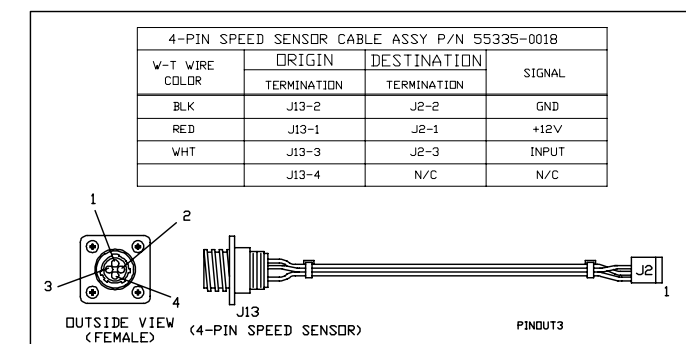
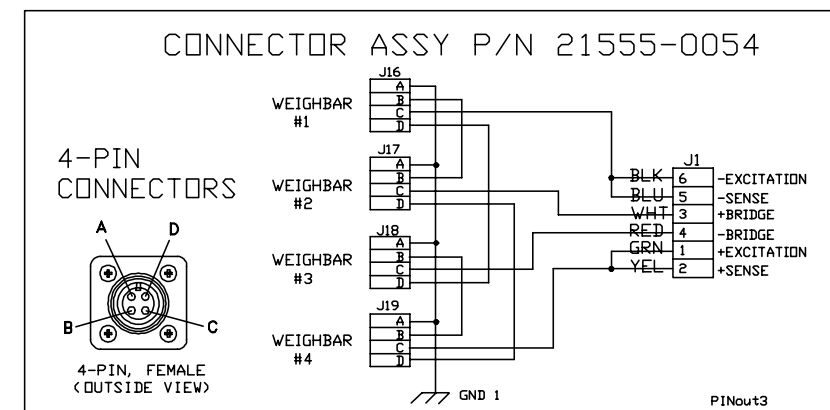
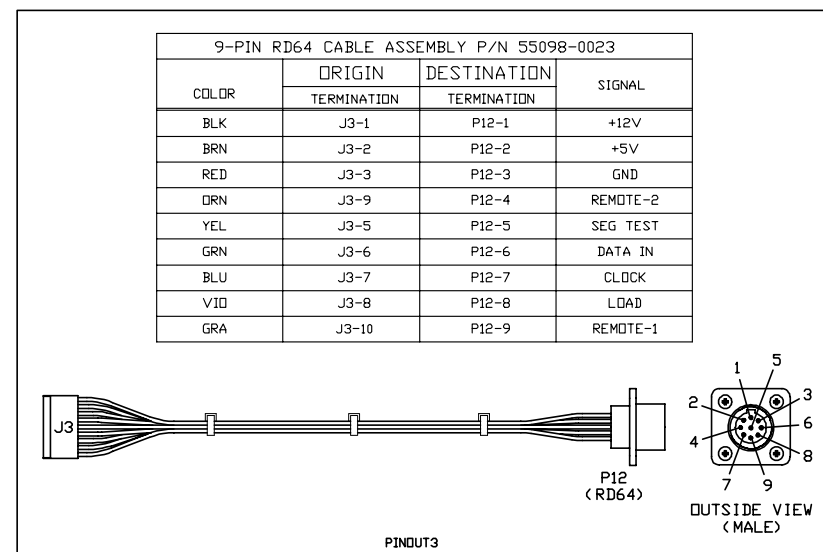
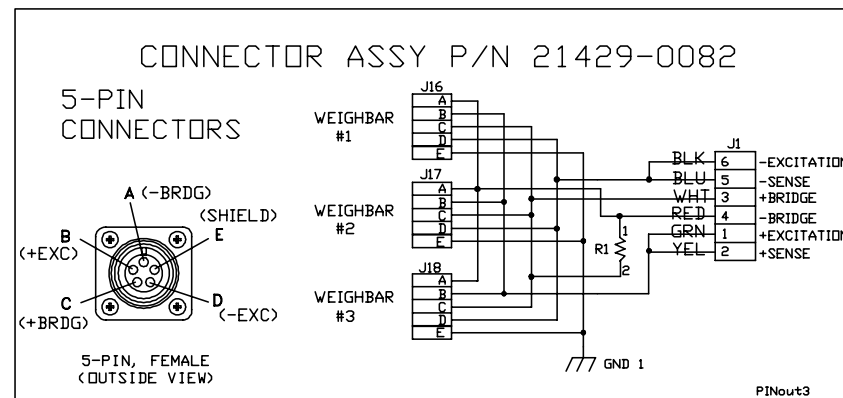
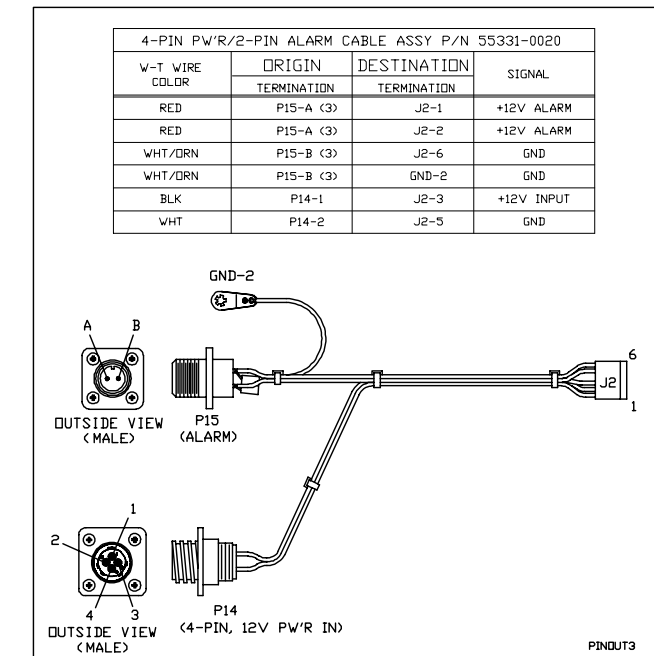
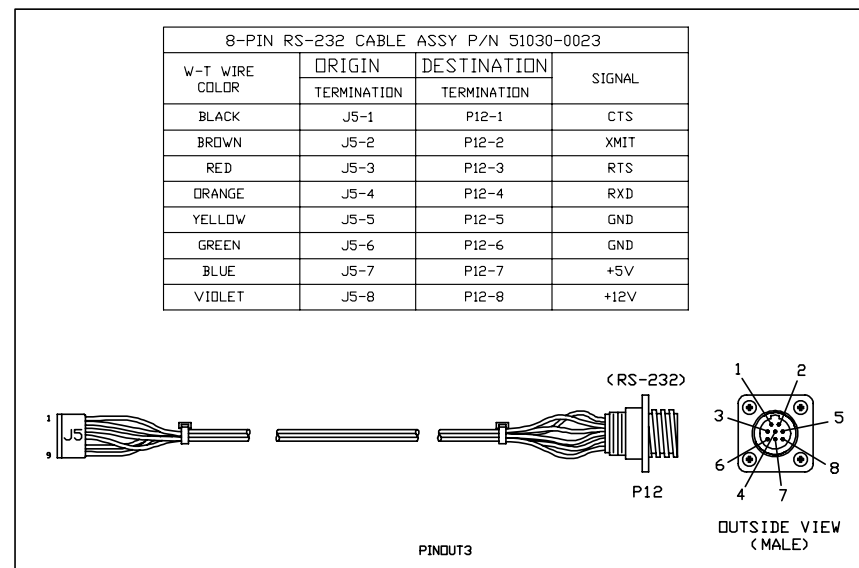
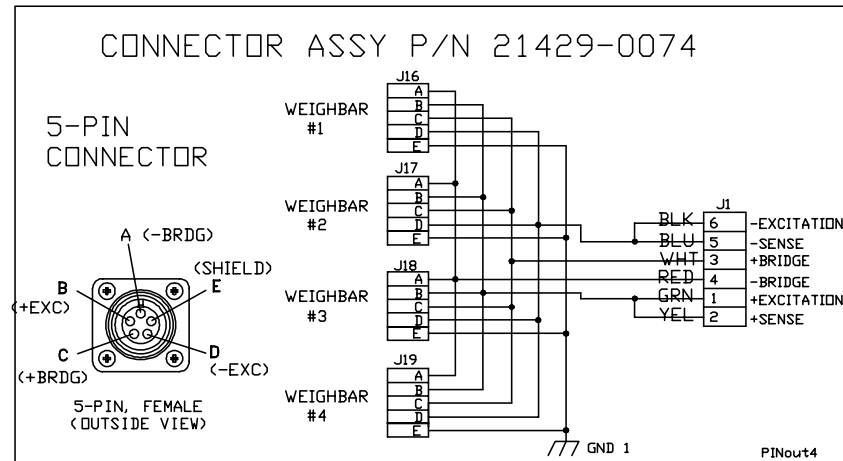
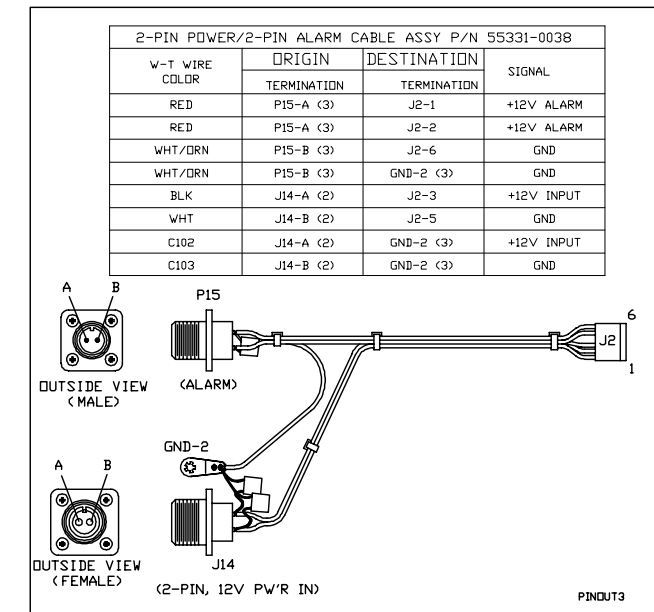

MODEL 2040 INDICATOR

RCV-64 RECEIVER ASSY, (optional)

COMPLETE RCV-64 ASSY:

P/N 55920-0019 (Std.), 55920-0027 (Euro-CE)
and XM64 TRANSMITTER (optional)

Parts List

ITEM NO.	DESCRIPTION	W-T P/N	QTY
1	RCV-64 Enclosure	55921-0018	1
2	Receiver Board, 315MHZ (std)	27290-5043	1
	Receiver Board 433MHZ (Euro-CE)	27290-5050	1
3	Cable Assy, 15' Length	55101-0085	1
4	Strain Relief (incl. hex nut)	15257-0032	1
5	XM64 Transmitter, 315MHz (std)	55096-0017	1
	XM64 Transmitter, 433MHz (Euro-CE)	55096-0025	1

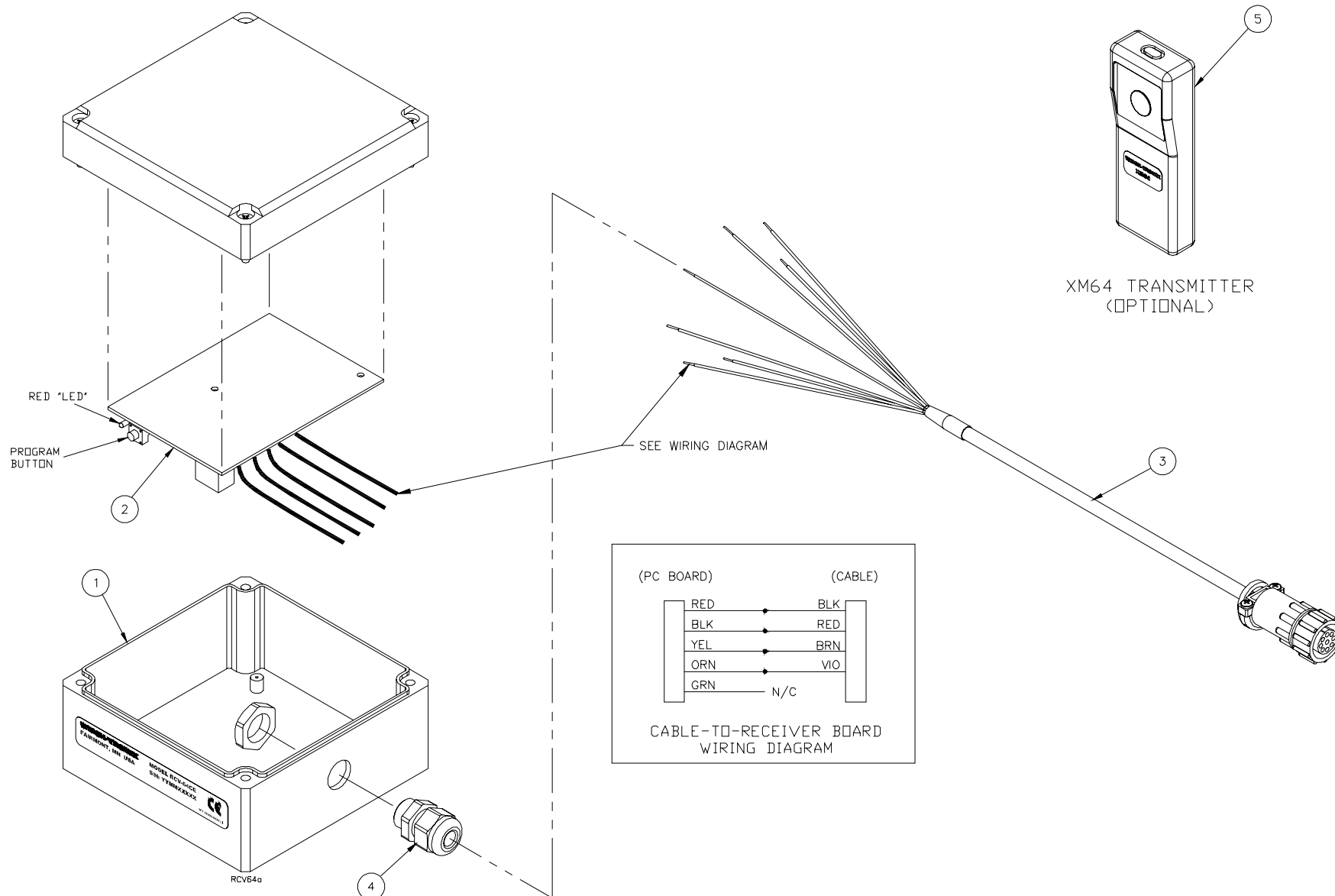

The following are instructions for the transmitter receiver kits used in the Model 2040/RD64 and the RCV-64 products. Please read through the following when debugging the XM-64 operation.

Checking Memory:

1. Press the program button on the receiver and hold for about two seconds until the Red LED illuminates, then release.
2. Count the number of times the Red LED blinks, this is the total number of transmitters programmed into the receiver.

Erasing Memory

1. Press the program button on the receiver and continue to hold it through the count of the transmitters.
2. Continue to Hold the button after the count until the indicator blinks one more time (about five seconds after the count)
3. All transmitters programmed into the memory will be erased.

Programming Memory

1. Press and release program button on the receiver.
2. Program indicator will light if there is room in memory for another transmitter. (32 transmitters max)
3. Press the button on the transmitter (XM64), indicator on receiver will flicker as signal is received.
4. Repeat the above three steps for each additional transmitter.

NOTE: The receiver can memorize each transmitter more than once. To prevent duplicate entries, program each transmitter into receiver only once.

RD64 REMOTE DISPLAY PARTS AND ASSEMBLY

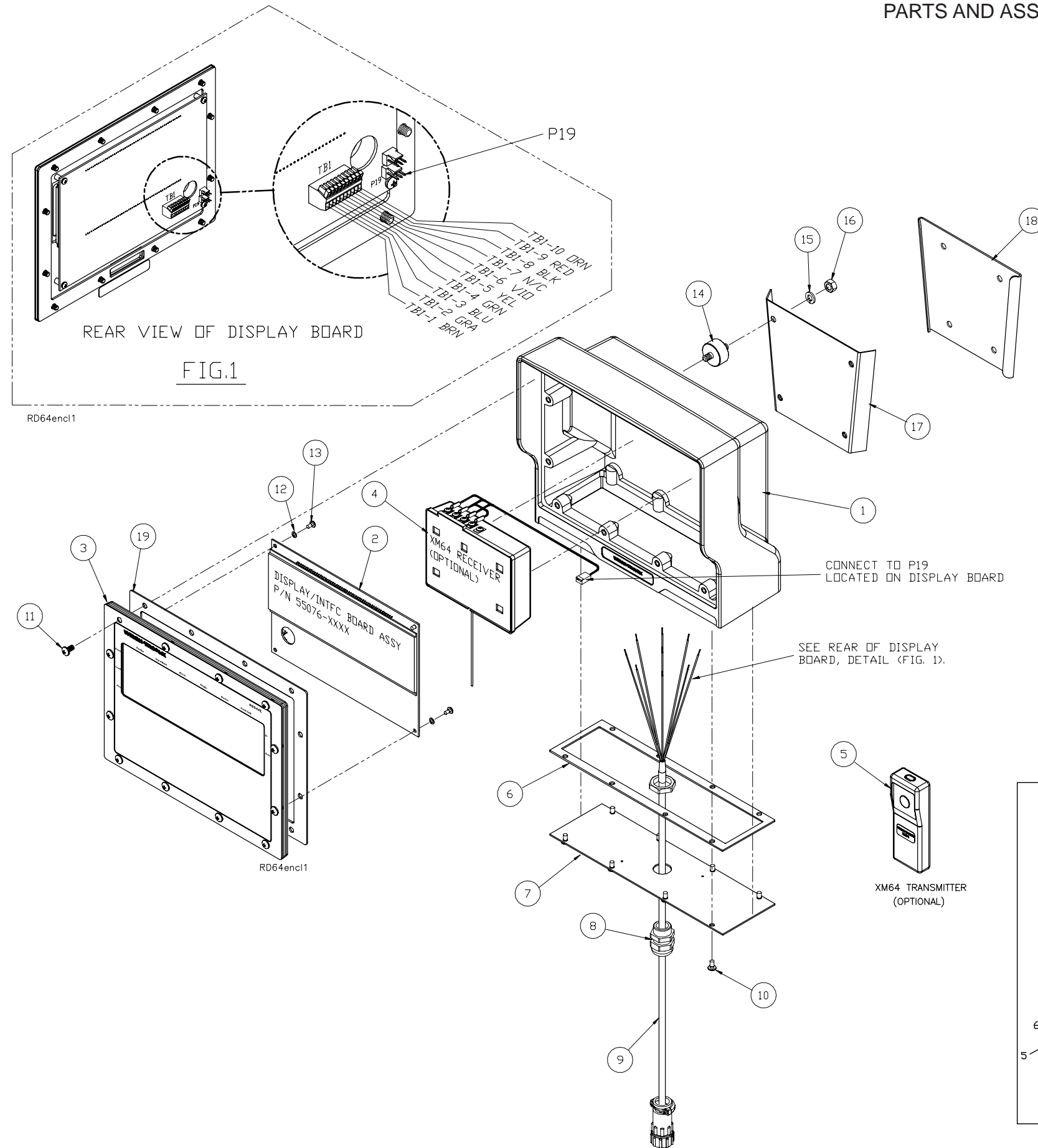

ITEM NO.	DESCRIPTION	W-T P/N	QTY
1	Enclosure	47017-0010	1
2	Display/Interface Board Assy (large display)	55076-0037	1
	Display/Interface Board Assy (std. display)	55076-0045	1
3	Keypad/Backer Plate Assy,XL (includes gasket)	55087-0034	1
	Keypad/Backer Plate Assy,std. (includes gasket)	55087-0059	1
4	XM64 Receiver, Std. version-315MHz (optional)	55095-0018	1
	XM64 Receiver, Euro version-433MHz (optional)	55095-0026	1
5	XM64 Transmitter, Std. version-315MHz (optional)	55096-0017	1
	XM64 Transmitter, Euro version-433MHz (optional)	55096-0025	1
6	Replacement Gasket, sticky one side (for item 7)	47695-0019	1
7	Bottom Plate	48413-0018	1
8	Strain Relief	15257-0040	1
9	Cable Assy, Indicator to RD64 (15 ft.)	55101-0085	1
	Cable Assy, Indicator to RD64 (30 ft.)	55101-0093	1
	Cable Assy, Indicator to RD64 (50 ft.)	55101-0101	1
	Cable Assy, Indicator to RD64 (75 ft.)	55101-0119	1
	Cable Assy, Indicator to RD64 (100 ft.)	55101-0127	1
	Cable Assy, Indicator to RD64 (150 ft.)	55101-0135	1
	Cable Assy, Indicator to RD64 (200 ft.)	55101-0143	1
10	Screw, #8-32 x .31"L	14473-0348	8
11	Screw, #10-32 x .38"L	14503-8030	12
12	Lock Washer, #6	14474-0032	4
13	Screw, #6-32 x .25"L	14473-0223	4
14	Rubber Vibration Mount	17807-0108	4
15	Lock Washer, .25"	14474-0198	4
16	Hex Nut, .25-20	14471-0209	4
17	Mtg. Bracket (attaches to Inclosure)	11899-0043	1
18	Mtg. Bracket (attaches to wall, etc.)	12339-0015	1
19	Replacement Gasket, sticky one side, (for item 3)	47694-0010	1

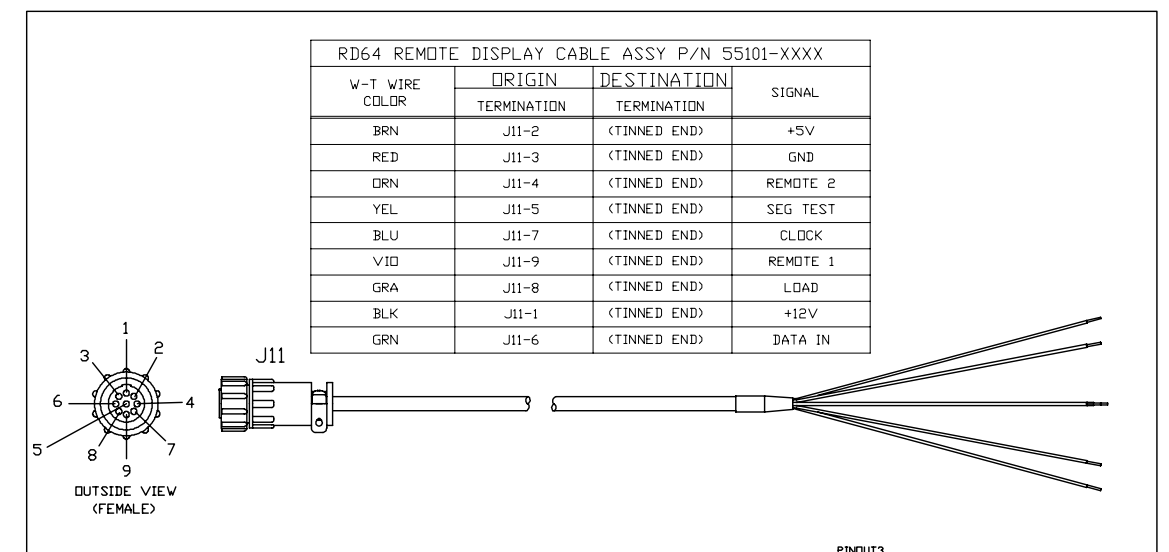

RD64 REMOTE DISPLAY
DISPLAY/INTERFACE BOARD ASSY
55076-0037

RD64XL Display Bd.
 (55076-0037)

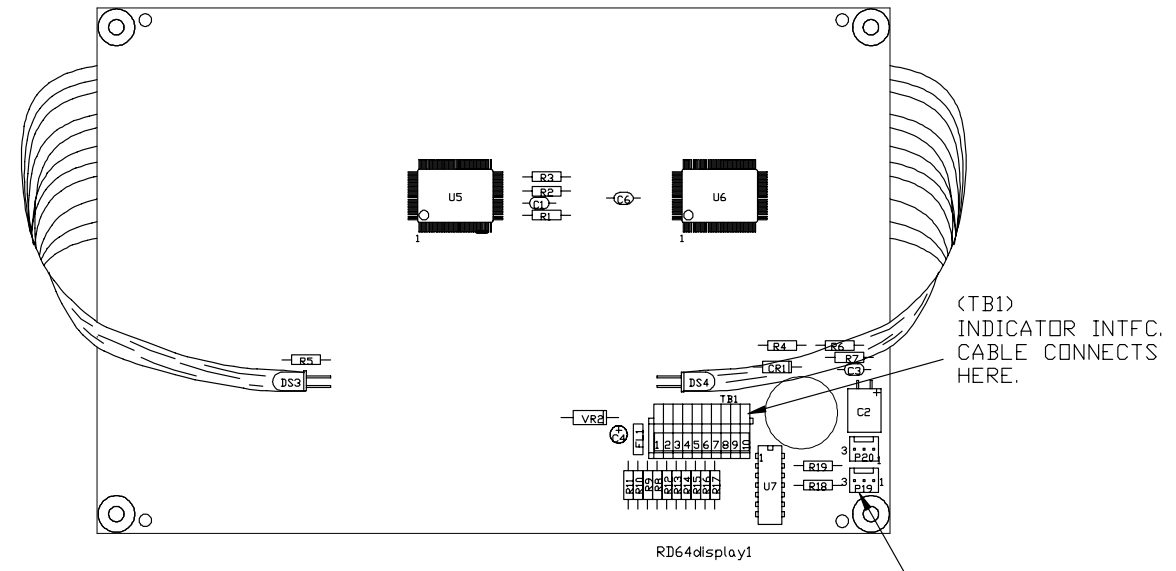

COMPONENT SIDE

(P19)
 OPTIONAL "XM64" TRANSMITTER
 CABLE ASSY CONNECTS HERE

(TB1)
 INDICATOR INTFC.
 CABLE CONNECTS
 HERE.

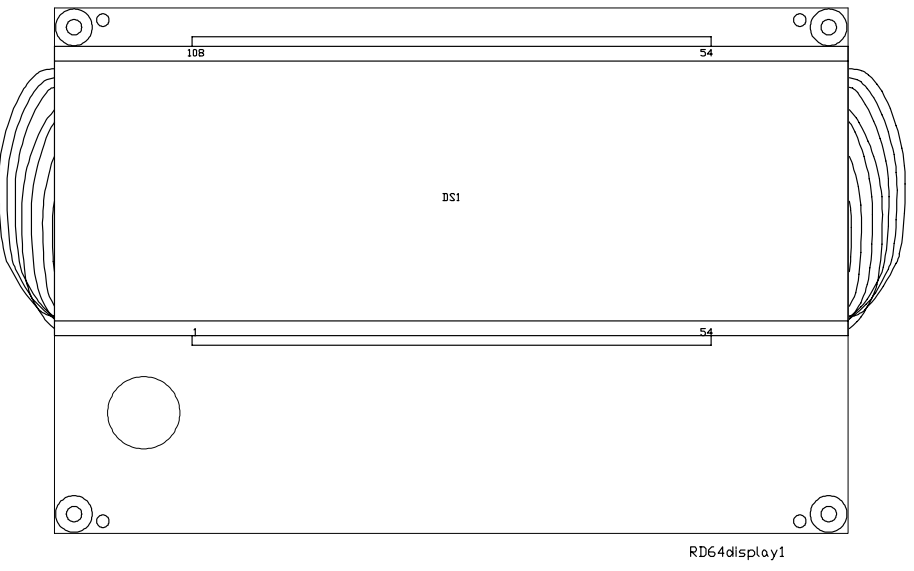

DISPLAY SIDE

RD64 Display Bd.
 (55076-0045)

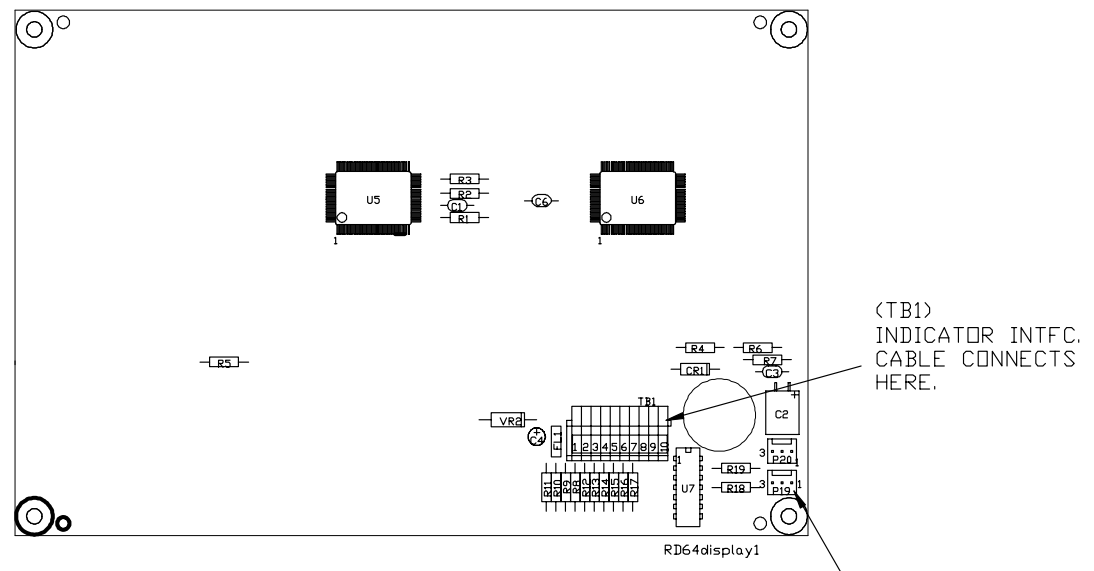

COMPONENT SIDE

(P19)
 OPTIONAL "XM64" TRANSMITTER
 CABLE ASSY CONNECTS HERE

(TB1)
 INDICATOR INTFC.
 CABLE CONNECTS
 HERE.

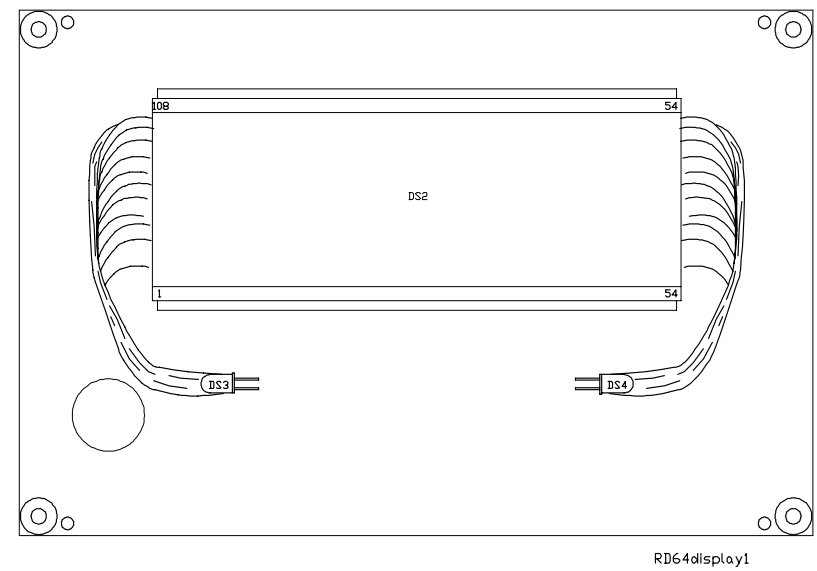

DISPLAY SIDE

RD64M REMOTE DISPLAY PARTS AND ASSEMBLY

NOTE:

APPLY RTV TO INSIDE OF CABLE STRAIN RELIEF (ITEM 9), SCREWS AND WASHERS ON BACK OF UNIT (ITEMS 2 & 3), AND THE FOUR SCREW HOLES ON THE COVER. APPLY A SMALL BEAD OF RTV AROUND THE ENTIRE LID BEFORE CLOSING AND TIGHTENING SCREWS. WIPE OFF EXCESS RTV THAT EXITS THE ENCLOSURE.

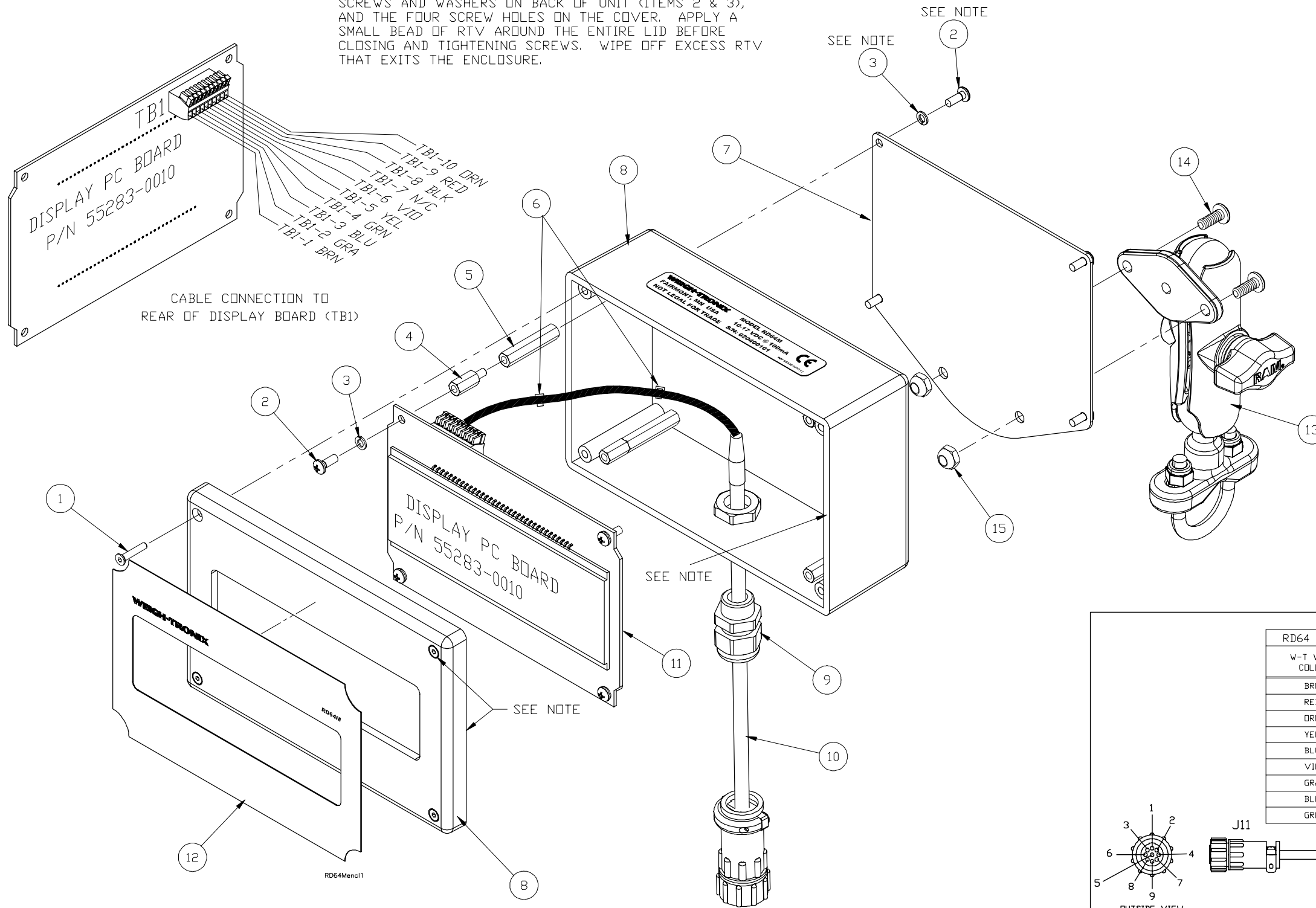

ITEM NO.	DESCRIPTION	W-T P/N	QTY
1	Screw	46572-0100	4
2	Screw, #8-32 x .38"L	14473-0249	8
3	Lock Washer, #6	14474-0032	8
4	Standoff, 6-32 x1 .50"L (F/F)	14510-0848	4
5	Standoff, 6-32 x .50"L (M/F)	15437-0449	4
6	Cable Tie	13762-0019	2
7	Mtg. Bracket (attaches to Inclosure)	55325-0010	1
8	Enclosure (includes front cover)	55329-0016	1
9	Strain Relief	15257-0032	1
10	Cable Assy, Indicator to RD64 (15 ft.)	55101-0085	1
	Cable Assy, Indicator to RD64 (30 ft.)	55101-0093	1
	Cable Assy, Indicator to RD64 (50 ft.)	55101-0101	1
	Cable Assy, Indicator to RD64 (75 ft.)	55101-0119	1
	Cable Assy, Indicator to RD64 (100 ft.)	55101-0127	1
	Cable Assy, Indicator to RD64 (150 ft.)	55101-0135	1
	Cable Assy, Indicator to RD64 (200 ft.)	55101-0143	1
11	RD64M Remote DisplayPC Board Assy	55283-0010	1
12	Front Panel Overlay	55104-0017	1
13	Mirror Mount Bracket (optional)	52652-0010	1
14	screw, (optional)	14473-0496	2
15	Locknut, (optional)	14464-0059	2
16	Mirror Mounting Kit (optional, incl. items 13,14,15)	53813-0014	1

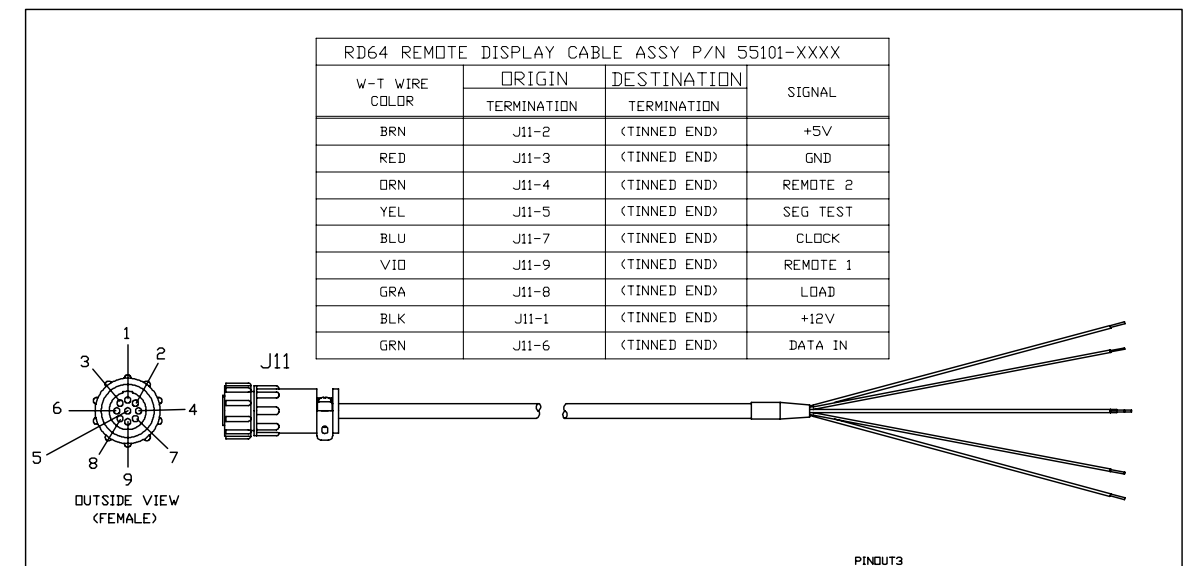

RD64M REMOTE DISPLAY
DISPLAY BOARD ASSY
 55283 -0010

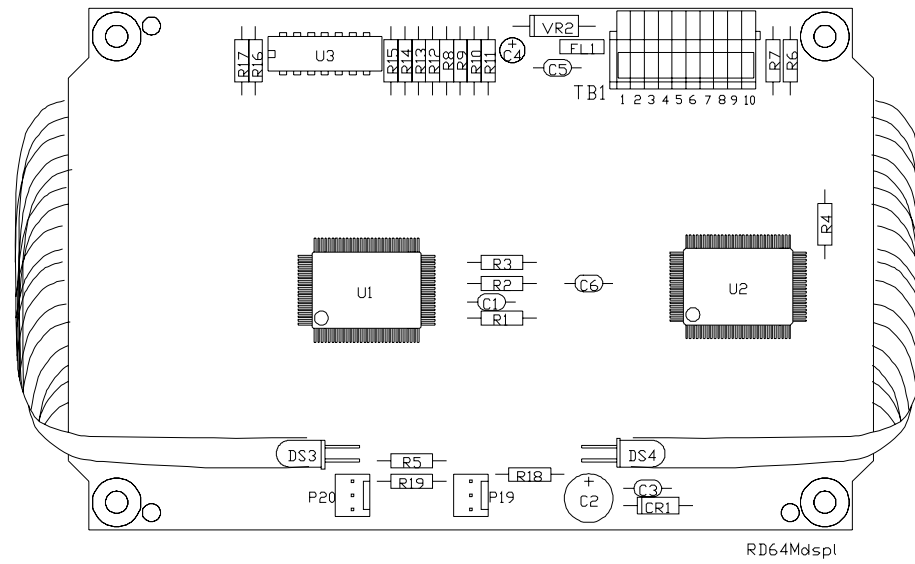

COMPONENT SIDE



DISPLAY SIDE

TDM-40 TRANSFER DATA MODULE (OPTIONAL)
P/N 55370-0014 AND CABLE PIN-OUTS

Down Loading Indicator to "TDM-40"

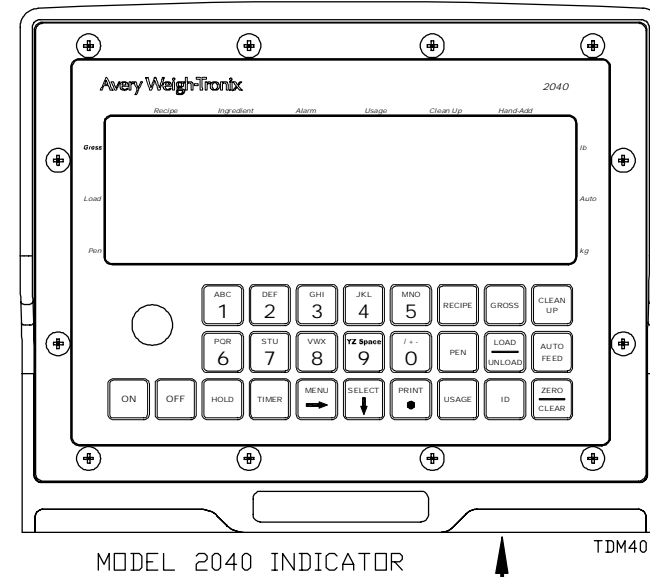

MODEL 2040 INDICATOR

TDM40

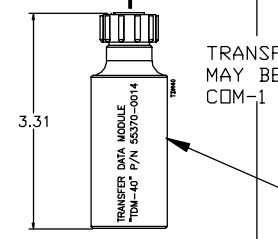

TRANSFER DATA MODULE "TDM-40" MAY BE CONNECTED DIRECTLY TO COM-1 OR COM-2 (BOTTOM PANEL).

"TDM-40" MODULE P/N 55370-0014

"TDM-40" MODULE P/N 55370-0014

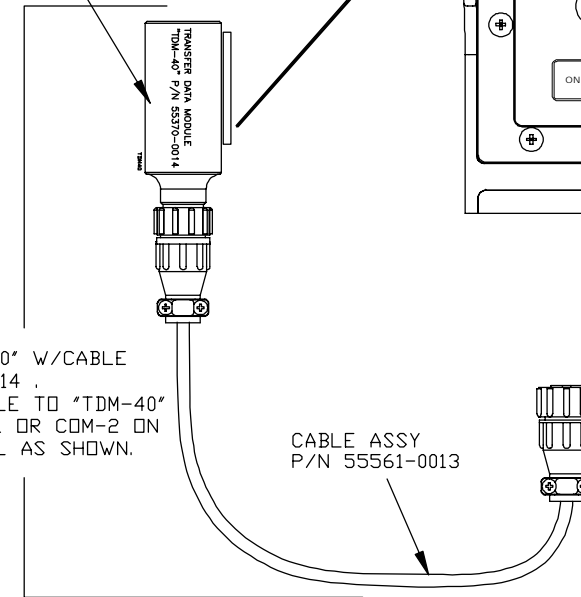

USING "TDM-40" W/CABLE P/N 55561-0014, CONNECT CABLE TO "TDM-40" AND TO COM-1 OR COM-2 ON BOTTOM PANEL AS SHOWN.

CABLE ASSY P/N 55561-0013

MODEL 2040 INDICATOR

TDM40

TO COM-1 OR 2

Down Loading "TDM-40" to Computer

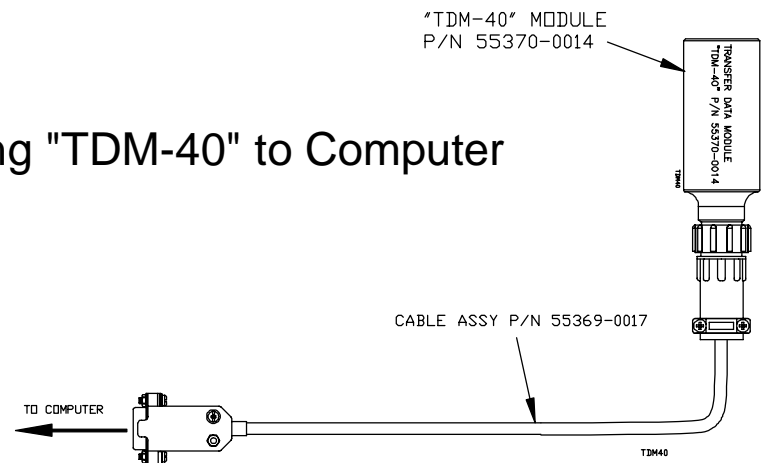

"TDM-40" MODULE P/N 55370-0014

CABLE ASSY P/N 55369-0017

TDM40

"TDM-40" -TO-COMPUTER CABLE ASSY P/N 55369-0017			
W-T WIRE COLOR	ORIGIN	DESTINATION	SIGNAL
	TERMINATION	TERMINATION	
RED	P11-3	J6-7	CTS
BRN	P11-1	J6-8	RTS
GRN	P11-7	J6-4	DTR
BLK	P11-5	J6-5	GND
BLK	P11-6		SHIELD
DRN	P11-2	J6-3	RCV
YEL	P11-4	J6-2	XMT

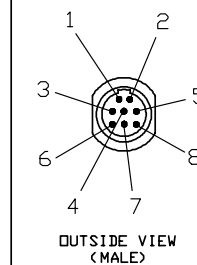

OUTSIDE VIEW (MALE)

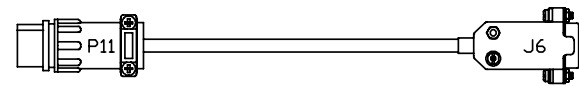

OUTSIDE VIEW (FEMALE)

PINOUT3

TDM-40 TO MODEL 1040 INDICATOR CABLE ASSY P/N 55561-0013			
W-T WIRE COLOR	ORIGIN	DESTINATION	SIGNAL
	TERMINATION	TERMINATION	
RED	P11-2	J6-2	XMT
GRN	P11-7	J6-7	+5V
BLK	P11-5	J6-5	GND
BLK		J6-6	SHIELD
DRN	P11-4	J6-4	RCV
YEL	P11-8	J6-8	+12V

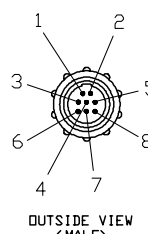

OUTSIDE VIEW (MALE)

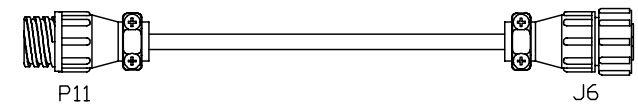

PINOUT3

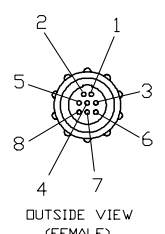

OUTSIDE VIEW (FEMALE)

MODEL 2040 INDICATOR OPTIONS / ACCESSORIES

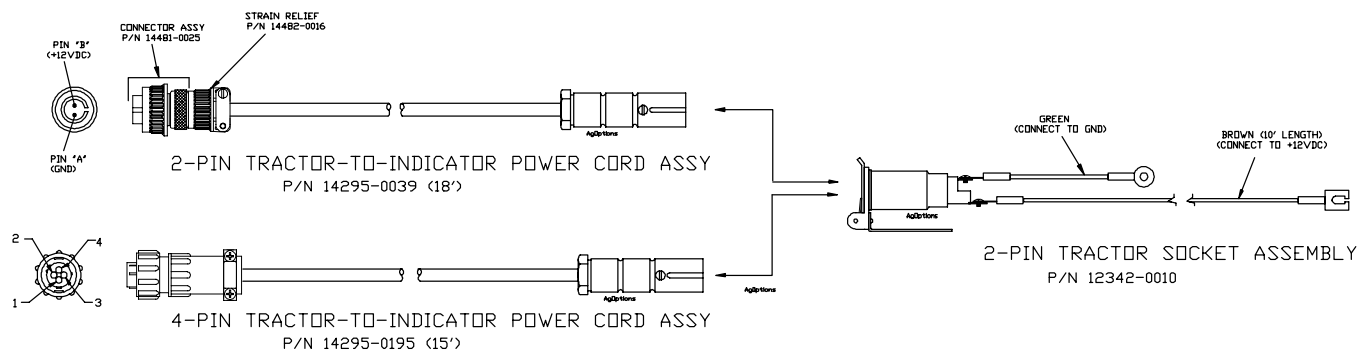

WALL MOUNT POWER SUPPLY
w/ W-T CONNECTOR (120VAC / 12VDC, 1 AMP)
P/N 46869-0011

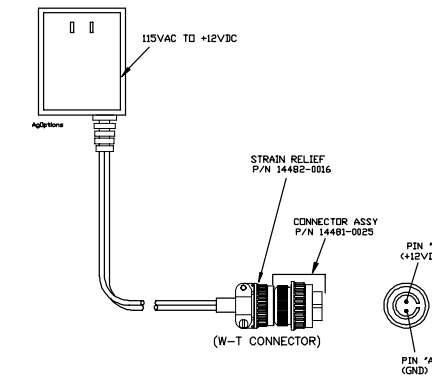

POWER CORD ASSY (W-T 2-PIN CONNECTOR)
(USED WITH POWER SUPPLY)
P/N 19266-0025(8'), -0041(12'), -0058(18')

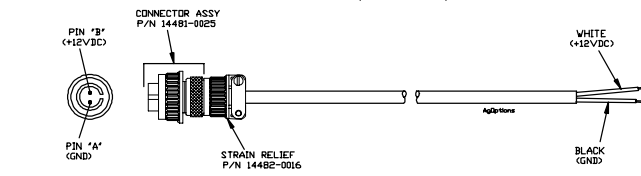

WALL MOUNT POWER SUPPLY
w/ AMP CONNECTOR (120VAC / 12VDC, 1 AMP)
P/N 50621-0020

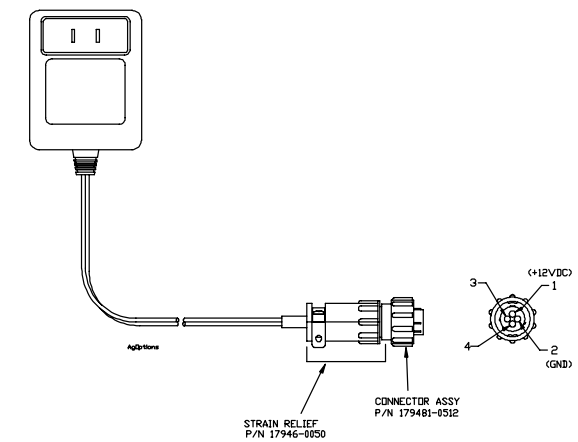

POWER CORD ASSY (AMP 4-PIN CONNECTOR)
(USED WITH POWER SUPPLY)
P/N 50474-0010(5'), -0028(10'), -0036(15'), -0044(20'), -0051(25')

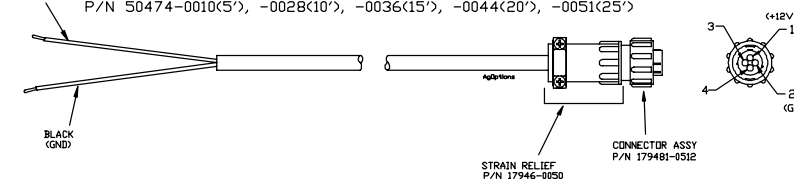

POWER SUPPLY P/N 28300-xxxx

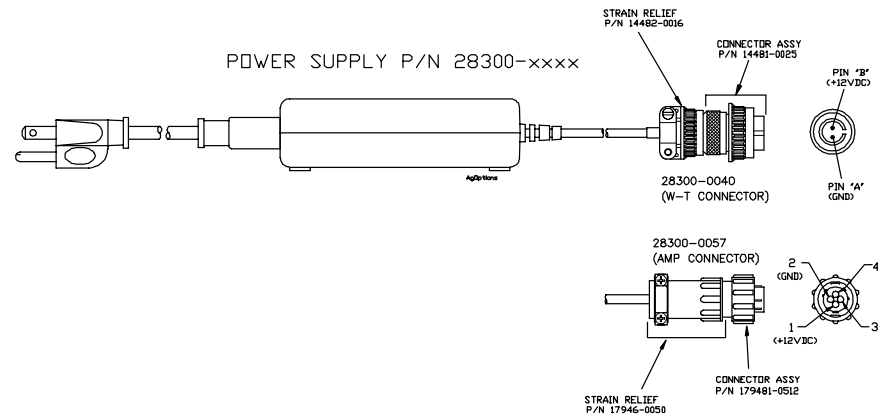

REMOTE AUDIO ALARM
P/N 14297-0011

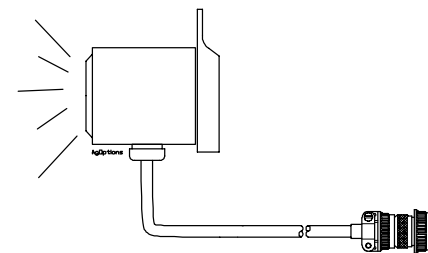

REMOTE LIGHT ALARM
P/N 14296-0012

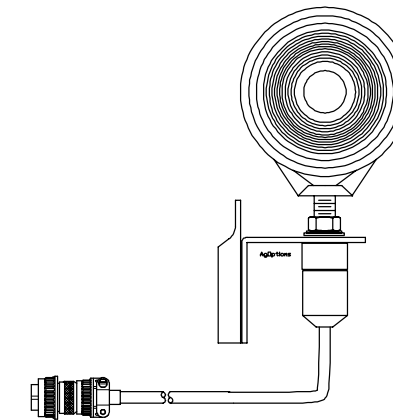

7-PIN TRACTOR INTERFACE CABLE
P/N 56067-0010 (INCL: 4-PIN FLAT AND 2-PIN W-T POWER CONNECTOR)
P/N 56067-0028 (INCL: 4-PIN FLAT, 2-PIN FLAT AND 2-PIN W-T POWER CONNECTOR)
P/N 56067-0036 (INCL: 4-PIN FLAT AND 4-PIN AMP POWER CONNECTOR)
P/N 56067-0044 (INCL: 4-PIN FLAT, 2-PIN FLAT AND 4-PIN AMP POWER CONNECTOR)

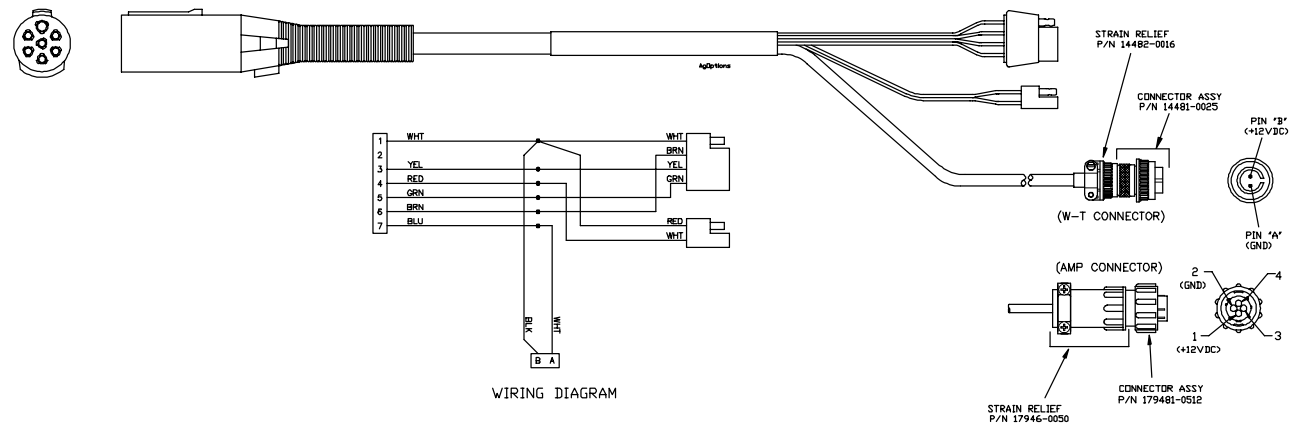

Standard Scale & Supply Company
25421 Glendale Avenue
Redford, MI 48239
313-255-6700
www.standardscale.com



Avery Weigh-Tronix
SCALES FOR AGRIBUSINESS