



A member of the
Avery Weigh-Tronix Group

60 Series

Indicators and Process Controllers



User Instructions

NORTH AMERICA

© Avery Weigh-Tronix, LLC 2009. All rights reserved.

No part of this publication may be reproduced, stored in an electronic retrieval system, or transmitted in any form or by any means, electronic, mechanical, photocopying, recording or otherwise without the prior written consent of the copyright owner, or as permitted by law or under license. Full acknowledgment of the source must be given. Avery Weigh-Tronix is a registered trade mark of the Avery Weigh-Tronix, LLC. This publication was correct at the time of going to print however, Avery Weigh-Tronix, LLC reserves the right to alter without notice the specification, design, price or conditions of supply of any product or service at any time.

All third party brands and product names used within this document are trademarks or registered trademarks of their respective holders.

All Weigh-Tronix / GSE products bearing the Factory Mutual seal are designed and manufactured according to the guidelines set forth by Factory Mutual Research. It is the responsibility of owners to gain approval from their insurance company for the suitability of the Weigh-Tronix equipment and installation for their particular environment.

Weigh-Tronix assumes no responsibility or liability either expressed or implied for the suitability of the Weigh-Tronix equipment for the owners' specific application or environment.

Table of Contents

Chapter 1 General information	3
About this manual	3
Text conventions	3
Operator interface	3
Special messages	3
Installation	5
Electrical installation	5
Pluggable equipment	5
Wet conditions	5
Routine maintenance	6
Cleaning the indicator	6
Training	6
Sharp objects	6
FCC and EMC declarations of compliance	7
Declaration of Conformancy	8
Common weighing applications	12
Indicator descriptions	12
Stainless Steel Enclosure	12
Features	12
Specifications	13
Enclosure Dimensions	14
Display	15
Keypad	17
Chapter 2 Installation	21
Table top or wall mounting	21
Model 460 Outline drawing	21
Model 465, 560, 562, 660, 662 Outline drawing	22
663 Outline drawing	22
663 Big box outline drawing	23
665 Outline drawing	23
Panel mounting	24
Model 460 outline drawing	24
Model 460 panel mount cutout	24
Model 465, 560, 562, 660, 662 panel mount outline drawing	25
Model 465, 560, 562, 660, 662 panel mount cutout	25
Model 665 panel mount outline drawing	26
Model 665 panel mount cutout	26
Chapter 3 Operation	27
Entering a tare value (model 460)	27
Entering a tare value (all models excluding model 460)	27
Time/Date (clock feature)	27
Entering the Time / Date (excluding model 460)	27
Entering the time / date (model 460)	28
Parts Counting	29
Simple keypad sample (model 460)	29
Negative piece sampling (model 460)	30
60 Series (excluding model 460)	30
Simple keypad sample	30
Negative piece sampling	31
Accumulation Mode	32
Performing Accumulations	32
Initializing Accumulation Totals	33

Accumulation Modes	33
Absolute and Percent Checkweighing	33
Set the high and low limits (excluding model 460)	34
Use checkweigh mode (excluding model 460)	34
Set the high and low limits (model 460)	34
Use checkweigh mode (model 460)	34
Truck I/O	35
Truck in	35
Truck out	35
Print ID's?	35
Clear one ID	36
Clear all	36
Store truck in tare weight	36
APW (average piece weight) lookup	37
Store APW	37
Get APW	37
Print APW'S	37
Clear one APW	38
Clear all APW'S	38
Fill (Batching)	38
Setup Outputs	39
Batching	39
Chapter 4 Troubleshooting	40
Information and error messages	40
Operational Mode Error Messages	40
Setup Mode Error Messages	41
Hardware Problem Error Messages	41
General Error Messages	42
Communications Error Messages	42
Other troubleshooting concerns	42
Data transmission	42
Displayed weight	42
Service	43

1 General information

1.1 About this manual

This manual is divided into chapters by the chapter number and the large text at the top of a page. Subsections are labeled as shown by the 1 and 1.1 headings shown above. The names of the chapter and the next subsection level appear at the top of alternating pages of the manual to remind you of where you are in the manual. The manual name and page numbers appear at the bottom of the pages.

This User Instruction manual contains basic operating information. Subjects covered include indicator installation, counting mode, accumulation mode, truck I/O operation, filling, time and date entry, and troubleshooting.

Subjects such as the setup mode and the macro programming language are beyond the scope of a user manual. Contact your GSE Distributor for more information.

1.1.1 Text conventions

Keystrokes are shown in brackets e.g. [PRINT] and reflect the case of the key being described. This applies to the keys on the indicator keypad.

Displayed messages appear in *italic* type and reflect the case of the displayed message.

1.1.2 Operator interface

Procedures often refer to information that appears on the 60 Series display as well as the keystrokes required to perform a certain function.

Display information

Display information may also appear within chapter text, such as the message *Need Code* or *Mot'n Delay*.

Keystrokes

Keystrokes listed within chapter text may also appear in brackets (i.e. [PRINT] or [CLR] + [SELECT]).

1.1.3 Special messages

Examples of special messages you will see in this manual are defined below. The signal words have specific meanings to alert you to additional information or the relative level of hazard.



DANGER!
THIS IS A DANGER SYMBOL.
DANGER MEANS THAT FAILURE TO FOLLOW SPECIFIC PRACTICES
OR PROCEDURES WILL CAUSE INJURY OR DEATH.



ELECTRICAL WARNING!
THIS IS AN ELECTRICAL WARNING SYMBOL.
ELECTRICAL WARNINGS MEAN THAT FAILURE TO FOLLOW SPECIFIC PRACTICES OR PROCEDURES MAY RESULT IN ELECTROCUTION, ARC BURNS, EXPLOSIONS OR OTHER HAZARDS THAT MAY CAUSE INJURY OR DEATH.



WARNING!
This is a Warning symbol.
Warnings mean that failure to follow specific practices and procedures may have major consequences such as injury or death.



CAUTION!
This is a Caution symbol.
Cautions give information about procedures that, if not observed, could result in damage to equipment or corruption to and loss of data.



NOTE: *This is a Note symbol. Notes give additional and important information, hints and tips that help you to use your product.*

1.2 Installation



DANGER: RISK OF ELECTRICAL SHOCK. NO USER SERVICEABLE PARTS. REFER TO QUALIFIED SERVICE PERSONNEL FOR SERVICE.

1.3 Electrical installation



CAUTION: The AC to DC Power Supply power cable must be connected to an earth-grounded electrical outlet. The electrical supply must have a circuit breaker with an appropriate rating to protect from over-current conditions.

For your protection, all electrical (110V or 230V) equipment used out of doors or in wet or damp conditions should be supplied from a correctly fused power source and protected by an approved ground fault protection device (RCD, GFCI etc.)

IF IN DOUBT SEEK ADVICE FROM A QUALIFIED ELECTRICIAN.

1.3.1 Pluggable equipment

Pluggable equipment must be installed near an easily accessible socket outlet.

1.3.2 Wet conditions

Under wet conditions, the plug must be connected to the final branch circuit via an appropriate socket / receptacle designed for washdown use.

Installations within the USA should use a cover that meets NEMA 3R specifications as required by the National Electrical Code under section 410-57. This allows the unit to be plugged in with a rain tight cover fitted over the plug.

Installations within Europe must use a socket which provides a minimum of IP56 protection to the plug / cable assembly. Care must be taken to make sure that the degree of protection provided by the socket is suitable for the environment.

1.4 Routine maintenance



IMPORTANT: This equipment must be routinely checked for proper operation and calibration.
Application and usage will determine the frequency of calibration required for safe operation.

Always turn off the indicator and isolate from the power supply before starting any routine maintenance to avoid the possibility of electric shock.

Make sure that it is placed securely on a flat and level surface.

1.5 Cleaning the indicator

Table 1.1 Cleaning DOs and DON'Ts



DO	DO NOT
Wipe down the outside of standard products with a clean cloth, moistened with water and a small amount of mild detergent	Attempt to clean the inside of the indicator
	Use harsh abrasives, solvents, scouring cleaners or alkaline cleaning solutions
Spray the cloth when using a proprietary cleaning fluid	Spray any liquid directly on to the display window

1.6 Training

Do not attempt to operate or complete any procedure on a indicator unless you have received the appropriate training or read the instruction books.

To avoid the risk of RSI (Repetitive Strain Injury), place the indicator on a surface which is ergonomically satisfactory to the user. Take frequent breaks during prolonged usage.

1.7 Sharp objects

Do not use sharp objects such as screwdrivers or long fingernails to operate the keys.

1.8 FCC and EMC declarations of compliance

United States

Table 1.2

This equipment has been tested and found to comply with the limits for a Class A digital device, pursuant to Part 15 of the FCC Rules. These limits are designed to provide reasonable protection against harmful interference when the equipment is operated in a commercial environment. This equipment generates, uses, and can radiate radio frequency energy and, if not installed and used in accordance with the instruction manual, may cause harmful interference to radio communications. Operation of this equipment in a residential area is likely to cause harmful interference in which case the user will be required to correct the interference at his own expense.

Canada

Table 1.3

This digital apparatus does not exceed the Class A limits for radio noise emissions from digital apparatus set out in the Radio Interference Regulations of the Canadian Department of Communications.

Le présent appareil numérique n'émet pas de bruits radioélectriques dépassant les limites applicables aux appareils numériques de la Classe A prescrites dans le Règlement sur le brouillage radioélectrique édicté par le ministère des Communications du Canada.

European Countries

Table 1.4

WARNING: This is a Class A product. In a domestic environment, this product may cause radio interference in which the user may be required to take adequate measures.

1.9 Declaration of Conformancy



Foundry Lane, Smethwick, West Midlands B66 2LP, England

	Declaration of Conformity Verklaring van Overeenstemming Déclaration de Conformité	Konformitätserklärung Dichiarazione di conformità Declaración de Conformidad
--	---	---

Manufacturer	Avery Weigh-Tronix Limited	
Type	GSE 460/465	
No. of EC type approval certificate	UK2853	
corresponds to the requirements of the following EC directives:		
EMC Directive	2004/108/EC	
Low Voltage Directive	2006/95/EC	
Non-Automatic Weighing Instruments Directive	2009/23/EC	
The applicable harmonised standards are:		
EN 45501 : 1994 EN 60950-1 : 2006	EN 61000-6-4 : 2007	
<p>Note 1: This declaration is only valid if the non-automatic weighing instrument was verified by the manufacturer or with a certificate of conformity issued by a notified body.</p> <p>Avery Weigh-Tronix Limited Reg. Office: Foundry Lane, Smethwick, West Midlands B66 2LP, England. Registered in England No: 595129</p>		

Fabrikant	Avery Weigh-Tronix Limited	
Type	GSE 460/465	
Nummer van de Verklaring van EG-typegoedkeuring	UK2853	
is in overeenstemming met de voorschriften van de volgende EG richtlijnen:		
EMC Richtlijn	2004/108/EC	
Laagspanningsrichtlijn	2006/95/EC	
Richtlijn niet-automatische weegwerktuigen	2009/23/EC	
Toegepaste geharmoniseerde normen:		
EN 45501 : 1994 EN 60950-1 : 2006	EN 61000-6-4 : 2007	
<p>Noot 1: Deze verklaring is alleen geldig indien het weegwerktuig door de fabrikant is geverifieerd, of met een Verklaring van overeenstemming, afgegeven door een bevoegde instantie.</p> <p>Avery Weigh-Tronix Limited Reg. Office: Foundry Lane, Smethwick, West Midlands B66 2LP, England. Registered in England No: 595129</p>		

Fabricant	Avery Weigh-Tronix Limited	
Type	GSE 460/465	
No. de certificat d'approbation de type CE	UK2853	
correspond aux exigences des directives CE suivantes :		
Directive CEM	2004/108/EC	
Directive Basse Tension	2006/95/EC	
Directive pour les instruments de pesage à fonctionnement non automatique	2009/23/EC	
Les normes harmonisées applicables sont :		
EN 45501 : 1994 EN 60950-1 : 2006	EN 61000-6-4 : 2007	
<p>Nota 1: Cette déclaration est valide seulement si l'instrument de pesage à fonctionnement non automatique a été vérifié par le fabricant ou avec une attestation de conformité délivrée par un organisme notifié.</p> <p>Avery Weigh-Tronix Limited Reg. Office: Foundry Lane, Smethwick, West Midlands B66 2LP, England. Registered in England No: 595129</p>		

Hersteller	Avery Weigh-Tronix Limited	
Typ	GSE 460/465	
Nr. der EG-Bauartzulassung	UK2853	
entspricht den Anforderungen folgender EG-Richtlinien:		
EMV-Richtlinie	2004/108/EC	
Niederspannungs Richtlinie	2006/95/EC	
Waagenrichtlinie für nichtselbsttätige Waagen	2009/23/EC	
Die angewendeten harmonisierten Normen sind:		
EN 45501 : 1994 EN 60950-1 : 2006	EN 61000-6-4 : 2007	
<p>Anmerkung 1: Diese Erklärung gilt nur, wenn die nichtselbsttätige Waage vom Hersteller geeicht wurde oder in Verbindung mit einer Konformitätsbescheinigung einer benannten Stelle.</p> <p>Avery Weigh-Tronix Limited Reg. Office: Foundry Lane, Smethwick, West Midlands B66 2LP, England. Registered in England No: 595129</p>		

Produttore	Avery Weigh-Tronix Limited	
Modello	GSE 460/465	
N. di certificato di approvazione di tipo CE	UK2853	
è conforme alle caratteristiche previste dalle seguenti direttive CE:		
Normativa EMC	2004/108/EC	
Normativa per la bassa tensione	2006/95/EC	
Normativa per strumenti di pesatura non automatici	2009/23/EC	
Le norme standard armonizzate e nazionali applicate sono:		
EN 45501 : 1994 EN 60950-1 : 2006	EN 61000-6-4 : 2007	
<p>Nota 1: Questa dichiarazione è valida solamente se lo strumento di pesatura non automatico è stato verificato dal produttore o provvisto di un certificato di conformità rilasciato da un ente riconosciuto.</p> <p>Avery Weigh-Tronix Limited Reg. Office: Foundry Lane, Smethwick, West Midlands B66 2LP, England. Registered in England No: 595129</p>		

Fabricante	Avery Weigh-Tronix Limited	
Tipo	GSE 460/465	
Número del certificado de aprobación de tipo CE	UK2853	
conforme a las exigencias de las siguientes directivas CE:		
Directiva CME	2004/108/EC	
Directiva de baja tensión	2006/95/EC	
Directiva para equipos de pesaje no automáticos	2009/23/EC	
Las normas armonizadas en vigor son:		
EN 45501 : 1994 EN 60950-1 : 2006	EN 61000-6-4 : 2007	
<p>Nota 1: Esta declaración es válida solamente si el equipo de pesaje no automático ha sido verificado por el fabricante o con certificado de conformidad emitido por un organismo notificado.</p> <p>Avery Weigh-Tronix Limited Reg. Office: Foundry Lane, Smethwick, West Midlands B66 2LP, England. Registered in England No: 595129</p>		

Signature/Name Handtekening/Naam Signature/Nom Unterschrift/Name Firma/Nombre Firma/Nombre	<p>S. Hine Head of R & D (UK)</p>	Authorised signatory for Avery Weigh-Tronix Limited Namens van Avery Weigh-Tronix Limited Signataire autorisé d'Avery Weigh-Tronix Limited Unterschriftsberechtigter für Avery Weigh-Tronix Limited Firmatario autorizzato per Avery Weigh-Tronix Limited Firmante autorizado para Avery Weigh-Tronix Limited	Date Datum Date Datum Date Fecha
		20 January 2010	

76501-319 Issue 1



Declaration of Conformity
Verklaring van Overeenstemming
Déclaration de Conformité

Konformitätserklärung
Dichiarazione di conformità
Declaración de Conformidad

Manufacturer	Avery Weigh-Tronix Limited
Type	GSE 560/562
No. of EC type approval certificate	UK2853
corresponds to the requirements of the following EC directives:	
EMC Directive	2004/108/EC
Low Voltage Directive	2006/95/EC
Non-Automatic Weighing Instruments Directive	2009/23/EC
The applicable harmonised standards are:	
EN 45501 : 1994 EN 60950-1 : 2006	EN 61000-6-4 : 2007
Note 1: This declaration is only valid if the non-automatic weighing instrument was verified by the manufacturer or with a certificate of conformity issued by a notified body. Avery Weigh-Tronix Limited Reg. Office: Foundry Lane, Smethwick, West Midlands B66 2LP, England. Registered in England No: 595129	

Fabrikant	Avery Weigh-Tronix Limited
Type	GSE 560/562
Nummer van de Verklaring van EG-typegoedkeuring	UK2853
is in overeenstemming met de voorschriften van de volgende EG richtlijnen:	
EMC Richtlijn	2004/108/EC
Laagspanningsrichtlijn	2006/95/EC
Richtlijn niet-automatische weegwerktuigen	2009/23/EC
Toegepaste geharmoniseerde normen:	
EN 45501 : 1994 EN 60950-1 : 2006	EN 61000-6-4 : 2007
Noot 1: Deze verklaring is alleen geldig indien het weegwerktuig door de fabrikant is geverifieerd, of met een Verklaring van overeenstemming, afgegeven door een bevoegde instantie. Avery Weigh-Tronix Limited Reg. Office: Foundry Lane, Smethwick, West Midlands B66 2LP, England. Registered in England No: 595129	

Fabricant	Avery Weigh-Tronix Limited
Type	GSE 560/562
No. de certificat d'approbation de type CE	UK2853
correspond aux exigences des directives CE suivantes :	
Directive CEM	2004/108/EC
Directive Basse Tension	2006/95/EC
Directive pour les instruments de pesage à fonctionnement non automatique	2009/23/EC
Les normes harmonisées applicables sont :	
EN 45501 : 1994 EN 60950-1 : 2006	EN 61000-6-4 : 2007
Nota 1 : Cette déclaration est valide seulement si l'instrument de pesage à fonctionnement non automatique a été vérifié par le fabricant ou avec une attestation de conformité délivrée par un organisme notifié. Avery Weigh-Tronix Limited Reg. Office: Foundry Lane, Smethwick, West Midlands B66 2LP, England. Registered in England No: 595129	

Hersteller	Avery Weigh-Tronix Limited
Typ	GSE 560/562
Nr. der EG-Bauartzulassung	UK2853
entspricht den Anforderungen folgender EG-Richtlinien:	
EMV-Richtlinie	2004/108/EC
Niederspannungs Richtlinie	2006/95/EC
Waagenrichtlinie für nichtselbsttätige Waagen	2009/23/EC
Die angewendeten harmonisierten Normen sind:	
EN 45501 : 1994 EN 60950-1 : 2006	EN 61000-6-4 : 2007
Anmerkung 1: Diese Erklärung gilt nur, wenn die nichtselbsttätige Waage vom Hersteller geeicht wurde oder in Verbindung mit einer Konformitätsbescheinigung einer benannten Stelle. Avery Weigh-Tronix Limited Reg. Office: Foundry Lane, Smethwick, West Midlands B66 2LP, England. Registered in England No: 595129	

Produttore	Avery Weigh-Tronix Limited
Modello	GSE 560/562
N. di certificato di approvazione di tipo CE	UK2853
è conforme alle caratteristiche previste dalle seguenti direttive CE:	
Normativa EMC	2004/108/EC
Normativa per la bassa tensione	2006/95/EC
Normativa per strumenti di pesatura non automatici	2009/23/EC
Le norme standard armonizzate e nazionali applicate sono:	
EN 45501 : 1994 EN 60950-1 : 2006	EN 61000-6-4 : 2007
Nota 1: Questa dichiarazione è valida solamente se lo strumento di pesatura non automatico è stato verificato dal produttore o provvisto di un certificato di conformità rilasciato da un ente riconosciuto. Avery Weigh-Tronix Limited Reg. Office: Foundry Lane, Smethwick, West Midlands B66 2LP, England. Registered in England No: 595129	

Fabricante	Avery Weigh-Tronix Limited
Tipo	GSE 560/562
Número del certificado de aprobación de tipo CE	UK2853
conforme a las exigencias de las siguientes directivas CE:	
Directiva CME	2004/108/EC
Directiva de baja tensión	2006/95/EC
Directiva para equipos de pesaje no automáticos	2009/23/EC
Las normas armonizadas en vigor son:	
EN 45501 : 1994 EN 60950-1 : 2006	EN 61000-6-4 : 2007
Nota 1: Esta declaración es válida solamente si el equipo de pesaje no automático ha sido verificado por el fabricante o con certificado de conformidad emitido por un organismo notificado. Avery Weigh-Tronix Limited Reg. Office: Foundry Lane, Smethwick, West Midlands B66 2LP, England. Registered in England No: 595129	

Signature/Name Handtekening/Naam Signature/Nom Unterschrift/Name Firma/Nome Firma/Nombre	 S. Hine Head of R & D (UK)	Authorised signatory for Avery Weigh-Tronix Limited Namens van Avery Weigh-Tronix Limited Signataire autorisé d'Avery Weigh-Tronix Limited Unterschriftsberechtigter für Avery Weigh-Tronix Limited Firmatario autorizzato per Avery Weigh-Tronix Limited Firmante autorizado para Avery Weigh-Tronix Limited	Date Datum Date Datum Data Fecha
		20 January 2010	

	Declaration of Conformity Verklaring van Overeenstemming Déclaration de Conformité	Konformitätserklärung Dichiarazione di conformità Declaración de Conformidad
---	---	---

Manufacturer	Avery Weigh-Tronix Limited
Type	GSE 560/660 Automatic Gravimetric Filling Instrument
No. of EC type examination certificate	UK/0126/0032
corresponds to the requirements of the following EC directives:	
Measuring Instruments Directive	2004/22/EC
EMC Directive	2004/108/EC
Low Voltage Directive	2006/95/EC
The applicable harmonised standards are:	
OIML R61 EN 60950-1 : 2006	EN 61000-6-4 : 2007
Avery Weigh-Tronix Limited Reg. Office: Foundry Lane, Smethwick, West Midlands B66 2LP, England. Registered in England No: 595129	

Fabrikant	Avery Weigh-Tronix Limited
Type	GSE 560/660 Automatic Gravimetric Filling Instrument
Nummer van de EG-onderzoeks certificaat	UK/0126/0032
is in overeenstemming met de voorschriften van de volgende EG richtlijnen:	
Richtlijn betreffende meetinstrumenten	2004/22/EC
EMC Richtlijn	2004/108/EC
Laagspanningsrichtlijn	2006/95/EC
Toegepaste geharmoniseerde normen:	
OIML R61 EN 60950-1 : 2006	EN 61000-6-4 : 2007
Avery Weigh-Tronix Limited Reg. Office: Foundry Lane, Smethwick, West Midlands B66 2LP, England. Registered in England No: 595129	

Fabricant	Avery Weigh-Tronix Limited
Type	GSE 560/660 Automatic Gravimetric Filling Instrument
No. de certificat d'examination de type CE	UK/0126/0032
correspond aux exigences des directives CE suivantes :	
Directive relative aux instruments de mesure	2004/22/EC
Directive CEM	2004/108/EC
Directive Basse Tension	2006/95/EC
Les normes harmonisées applicables sont :	
OIML R61 EN 60950-1 : 2006	EN 61000-6-4 : 2007
Avery Weigh-Tronix Limited Reg. Office: Foundry Lane, Smethwick, West Midlands B66 2LP, England. Registered in England No: 595129	

Hersteller	Avery Weigh-Tronix Limited
Typ	GSE 560/660 Automatic Gravimetric Filling Instrument
Nr. des EG-Bauartprüfscheins	UK/0126/0032
entspricht den Anforderungen folgender EG-Richtlinien:	
Richtlinie für Messgeräte	2004/22/EC
EMV-Richtlinie	2004/108/EC
Niederspannungsrichtlinie	2006/95/EC
Die angewendeten harmonisierten Normen sind:	
OIML R61 EN 60950-1 : 2006	EN 61000-6-4 : 2007
Avery Weigh-Tronix Limited Reg. Office: Foundry Lane, Smethwick, West Midlands B66 2LP, England. Registered in England No: 595129	

Produttore	Avery Weigh-Tronix Limited
Modello	GSE 560/660 Automatic Gravimetric Filling Instrument
N. di certificato di verifica di tipo CE	UK/0126/0032
è conforme alle caratteristiche previste dalle seguenti direttive CE:	
Direttiva relativa agli strumenti di misura	2004/22/EC
Normativa EMC	2004/108/EC
Normativa per la bassa tensione	2006/95/EC
Le norme standard armonizzate e nazionali applicate sono:	
OIML R61 EN 60950-1 : 2006	EN 61000-6-4 : 2007
Avery Weigh-Tronix Limited Reg. Office: Foundry Lane, Smethwick, West Midlands B66 2LP, England. Registered in England No: 595129	

Fabricante	Avery Weigh-Tronix Limited
Tipo	GSE 560/660 Automatic Gravimetric Filling Instrument
Número del certificado de evaluación de tipo CE	UK/0126/0032
conforme a las exigencias de las siguientes directivas CE:	
Directiva relativa a los instrumentos de medida	2004/22/EC
Directiva CME	2004/108/EC
Directiva de baja tensión	2006/95/EC
Las normas armonizadas en vigor son:	
OIML R61 EN 60950-1 : 2006	EN 61000-6-4 : 2007
Avery Weigh-Tronix Limited Reg. Office: Foundry Lane, Smethwick, West Midlands B66 2LP, England. Registered in England No: 595129	

Signature/Name	 S. Hine Head of R & D (UK)	Authorised signatory for Avery Weigh-Tronix Limited	Date
Handtekening/Naam		Namens van Avery Weigh-Tronix Limited	Datum
Signature/Nom		Signataire autorisé d'Avery Weigh-Tronix Limited	Date
Unterschrift/Name		Unterschriftsberechtigter für Avery Weigh-Tronix Limited	Datum
Firma/Nome		Firmatario autorizzato per Avery Weigh-Tronix Limited	Data
Firma/Nombre	Firmante autorizado para Avery Weigh-Tronix Limited	20 January 2010	Fecha

	Declaration of Conformity Verklaring van Overeenstemming Déclaration de Conformité	Konformitätserklärung Dichiarazione di conformità Declaración de Conformidad
---	---	---

Manufacturer Type No. of EC type approval certificate	Avery Weigh-Tronix Limited GSE 660/662/665 UK2853
corresponds to the requirements of the following EC directives:	
EMC Directive	2004/108/EC
Low Voltage Directive	2006/95/EC
Non-Automatic Weighing Instruments Directive	2009/23/EC
The applicable harmonised standards are:	
EN 45501 : 1994 EN 60950-1 : 2006	EN 61000-6-4 : 2007
Note ¹ : This declaration is only valid if the non-automatic weighing instrument was verified by the manufacturer or with a certificate of conformity issued by a notified body. Avery Weigh-Tronix Limited Reg. Office: Foundry Lane, Smethwick, West Midlands B66 2LP, England. Registered in England No: 595129	

Fabrikant Type Nummer van de Verklaring van EG-typegoedkeuring	Avery Weigh-Tronix Limited GSE 660/662/665 UK2853
is in overeenstemming met de voorschriften van de volgende EG richtlijnen:	
EMC Richtlijn	2004/108/EC
Laagspanningsrichtlijn	2006/95/EC
Richtlijn niet-automatische weegwerktuigen	2009/23/EC
Toegepaste geharmoniseerde normen:	
EN 45501 : 1994 EN 60950-1 : 2006	EN 61000-6-4 : 2007
Noot ¹ : Deze verklaring is alleen geldig indien het weegwerktuig door de fabrikant is geleverd, of met een Verklaring van overeenstemming, afgegeven door een bevoegde instantie. Avery Weigh-Tronix Limited Reg. Office: Foundry Lane, Smethwick, West Midlands B66 2LP, England. Registered in England No: 595129	

Fabricant Type No. de certificat d'approbation de type CE	Avery Weigh-Tronix Limited GSE 660/662/665 UK2853
correspond aux exigences des directives CE suivantes :	
Directive CEM	2004/108/EC
Directive Basse Tension	2006/95/EC
Directive pour les instruments de pesage à fonctionnement non automatique	2009/23/EC
Les normes harmonisées applicables sont :	
EN 45501 : 1994 EN 60950-1 : 2006	EN 61000-6-4 : 2007
Nota ¹ : Cette déclaration est valide seulement si l'instrument de pesage à fonctionnement non automatique a été vérifié par le fabricant ou avec une attestation de conformité délivrée par un organisme notifié. Avery Weigh-Tronix Limited Reg. Office: Foundry Lane, Smethwick, West Midlands B66 2LP, England. Registered in England No: 595129	

Hersteller Typ Nr. der EG-Bauartzulassung	Avery Weigh-Tronix Limited GSE 660/662/665 UK2853
entspricht den Anforderungen folgender EG-Richtlinien:	
EMV-Richtlinie	2004/108/EC
Niederspannungs Richtlinie	2006/95/EC
Waagenrichtlinie für nichtselbsttätige Waagen	2009/23/EC
Die angewendeten harmonisierten Normen sind:	
EN 45501 : 1994 EN 60950-1 : 2006	EN 61000-6-4 : 2007
Anmerkung ¹ : Diese Erklärung gilt nur, wenn die nichtselbsttätige Waage vom Hersteller geeicht wurde oder in Verbindung mit einer Konformitätsbescheinigung einer benannten Stelle. Avery Weigh-Tronix Limited Reg. Office: Foundry Lane, Smethwick, West Midlands B66 2LP, England. Registered in England No: 595129	

Produttore Modello N. di certificato di approvazione di tipo CE	Avery Weigh-Tronix Limited GSE 660/662/665 UK2853
è conforme alle caratteristiche previste dalle seguenti direttive CE:	
Normativa EMC	2004/108/EC
Normativa per la bassa tensione	2006/95/EC
Normativa per strumenti di pesatura non automatici	2009/23/EC
Le norme standard armonizzate e nazionali applicate sono:	
EN 45501 : 1994 EN 60950-1 : 2006	EN 61000-6-4 : 2007
Nota ¹ : Questa dichiarazione è valida solamente se lo strumento di pesatura non automatico è stato verificato dal produttore o provvisto di un certificato di conformità rilasciato da un ente riconosciuto. Avery Weigh-Tronix Limited Reg. Office: Foundry Lane, Smethwick, West Midlands B66 2LP, England. Registered in England No: 595129	

Fabricante Tipo Número del certificado de aprobación de tipo CE	Avery Weigh-Tronix Limited GSE 660/662/665 UK2853
conforme a las exigencias de las siguientes directivas CE:	
Directiva CME	2004/108/EC
Directiva de baja tensión	2006/95/EC
Directiva para equipos de pesaje no automáticos	2009/23/EC
Las normas armonizadas en vigor son:	
EN 45501 : 1994 EN 60950-1 : 2006	EN 61000-6-4 : 2007
Nota ¹ : Esta declaración es válida solamente si el equipo de pesaje no automático ha sido verificado por el fabricante o con certificado de conformidad emitido por un organismo notificado. Avery Weigh-Tronix Limited Reg. Office: Foundry Lane, Smethwick, West Midlands B66 2LP, England. Registered in England No: 595129	

Signature/Name Handtekening/Naam Signature/Nom Unterschrift/Name Firma/Nombre	 S. Hine Head of R & D (UK)	Authorised signatory for Avery Weigh-Tronix Limited Namens van Avery Weigh-Tronix Limited Signataire autorisé d'Avery Weigh-Tronix Limited Unterschriftsberechtigter für Avery Weigh-Tronix Limited Firmatario autorizzato per Avery Weigh-Tronix Limited Firmante autorizado para Avery Weigh-Tronix Limited	Date Datum Date Datum Data Fecha
			20 January 2010

1.10 Common weighing applications

Typical weighing applications for GSE 60 Series indicators and controllers include:

- | Small parts weighing
- | Large parts weighing
- | Truck loading (truck in / truck out)
- | Tank weighing
- | Parts counting
- | Process control
- | Inventory control
- | Order picking
- | Floor and hopper scales control
- | Conveyor weigh systems control
- | Batching (mixing)
- | Check weighing

1.11 Indicator descriptions

All 60 Series models excluding the 663 come with a swivel bracket for positioning on a tabletop or mounting to any fixed surface.

GSE offers many options to enhance the 60 Series of indicators. The number of options that can be used varies among the different models.

See the Specifications section on page [13](#) for enclosure dimensions.

1.11.1 Stainless Steel Enclosure

The stainless steel versions excluding the 663 are also available in panel-mount. The model 663 is also available in a powder coat mild steel enclosure.

60 Series instruments are supplied in a NEMA 4X (IP66) enclosure and may be used in a wash-down environment. Care must be taken to ensure that the AC power socket outlet is properly protected.

The keypad is made of silicon rubber. It may be cleaned periodically with a soft damp non-abrasive cloth. The display window is made from a polycarbonate material, which may scratch due to aggressive cleaning. Care must be taken to avoid such damage.

1.12 Features

GSE 60 Series instruments share the following standard features:

- | Sealed elastomer keypad for protection against harsh environments
- | AC power
- | DC power
- | Front panel calibration and linearization execution

- | Capacitive sealed keypad
- | Selectable weighing units: pounds, kilograms, ounces, grams, etc.
- | Programmable RS-232 communications software
- | Remote display support capability
- | Expandable memory for increased data storage
- | Battery-backed time and date clock
- | Enclosure protects against water ingress

1.13 Specifications

Performance

Full Scale	Selectable
Resolution	100,000 displayed (+/-500,000 internal)
Display Update	Selectable 0.05-20 seconds
A/D Conversion	60 Hz
Non-Linearity	0.005% of full scale (input dependent)
Zero Track	0.05-20.0 displayed divisions
Zero Range	Selectable from 0.01-100% of full scale
Calibration	Selectable
Linearization	Ten multi-point calibration for linearization
Division Size	.00001 through 500

Electrical

Power input	90-250 VAC, 50/60 Hz; 10-32 VDC
Fuse	0.8 amp time lag (AC powered)

Load Cell Input

Connections	4 lead or 6 lead with sense, jumper selectable
Power	Fourteen 350-ohm cells (560 and 660 Series)
Power	Twelve 350-ohm cells (460 Series)
Signal Range	0.1 to 20 mV/V at full scale
Excitation	10 VDC, short circuit protected
Current	400 mA maximum

Communications

Bi-directional RS-232 serial ports
 Transmit output: continuous transmit, on request, motion inhibited
 Selectable baud rate
 Selectable protocol
 Selectable data formatting

Display

Vacuum fluorescent, 0.75 in. high digits

240 x 64 LCD display, 5 in. x 1.34 in. usable area

240 x 128 LCD display, 4.72 in. x 2.52 in. usable area

Four-line by 20-character alphanumeric display, 0.20 in. high digits

Increments 1, 2, 5, 10, 20, 50, 100, 500

Selectable decimal point

Display values -99,999 through 999,999

Polarity "-" sign to left of most significant active digit

Status indicator 10-character dot matrix prompting display

1.13.1 Enclosure Dimensions

Model	Width	Height	Depth
465/560/562/660/662 Stainless Steel	11 in*(279 mm)	9 in*(228 mm)	4.4 in*(112 mm)
460 Stainless Steel	11 in*(279 mm)	8 in*(203 mm)	4 in*(101 mm)
460 Panel Mount	10 in**(254 mm)	7 in**(177 mm)	4 in**(101 mm)
465/560/562/660/661/662 Panel Mount	10 in**(254 mm)	9 in**(228 mm)	4.4 in**(112 mm)
663 Stainless Steel, Mild Steel	16.18 in**(411 mm)	22.5 in**(571.5 mm)	9.28 in**(235.7 mm)
663 Big Box Stainless Steel, Mild Steel	24 in**(609 mm)	32 in**(812 mm)	9.28 in**(235.7 mm)
665 Stainless Steel	11.07 in*(281.20 mm)	12.16 in*(308.9 mm)	4.70 in*(119.4 mm)
mm =millimeter; in = inch *Includes mounting stand. **Includes mounting flange.			

1.14 Display

Display types differ according to model. The table below describes the display(s) offered for each controller.

Model	Display
460 465 560 660	6 digit, Vacuum Florescent display (VFD) 0.75" (19mm) height with 2 x 5 matrix
661	4-line by 20-character alphanumeric VF display (8mm)
562 662	240 x 64 backlit LCD graphic, 3 font sizes
663	Available in two versions:
	6 digit, Vacuum Florescent display (VFD) and 4-line by 20 character alphanumeric VF display
	or 240 x 128 backlit LCD display
665	Available in two versions:
	6 digit, Vacuum Florescent display (VFD) and 4-line by 20 character alphanumeric VF display
	or 240 x 128 backlit LCD display

The vacuum fluorescent (VF) display is divided into two sections: a large, six-digit numeric area to the left, and a smaller, two-line-by-five-character dot matrix area to the right.

The large digit area displays numeric data, such as gross weight, net weight or tare weight.

The dot matrix area has several purposes:

- 1 The first two characters on the upper line show the weighing units of the displayed data.
- 1 The last three characters on the upper line show a center zero (-- >0< --) condition at times.
- 1 The lower line of the dot matrix area specifies the type of data, such as Gross, Net, Tare, etc.

The dot matrix area also displays specific messages during controller operation and setup.

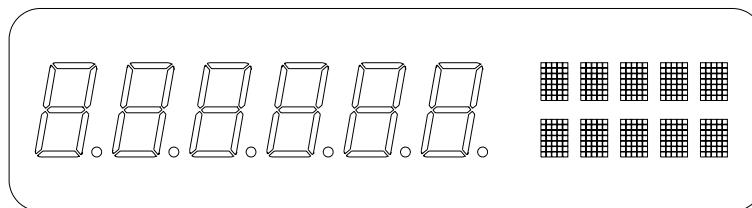

Figure 1.1 Model 460, 465, 560 and 660 Six Digit VFD

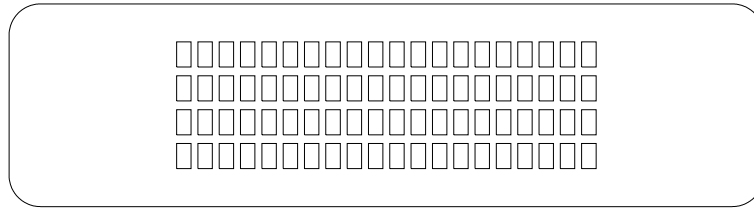

Figure 1.2 Model 661 4x20 VFD

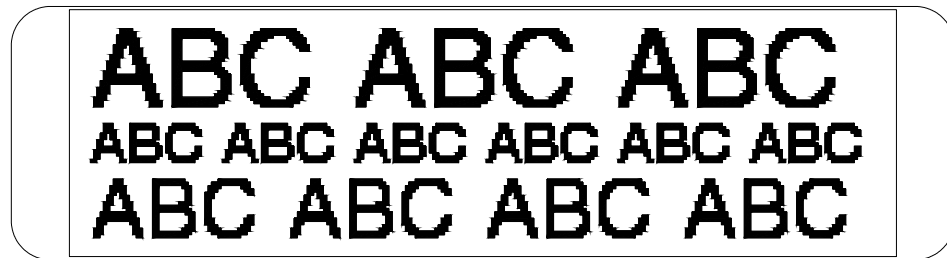

Figure 1.3 Model 562 and 662 8x20 LCD

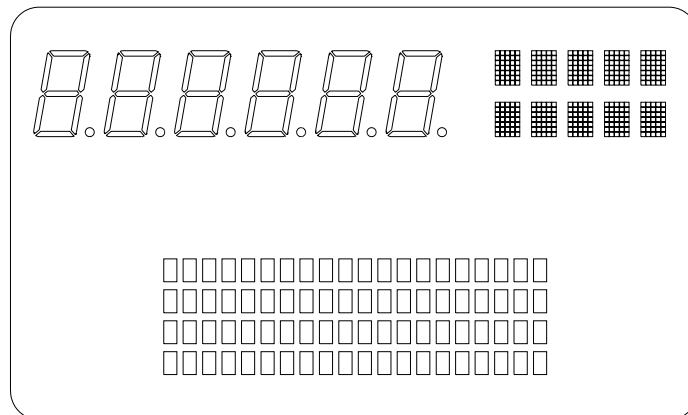

Figure 1.4 Model 663 and 665 Six Digit and 4x20 VFD

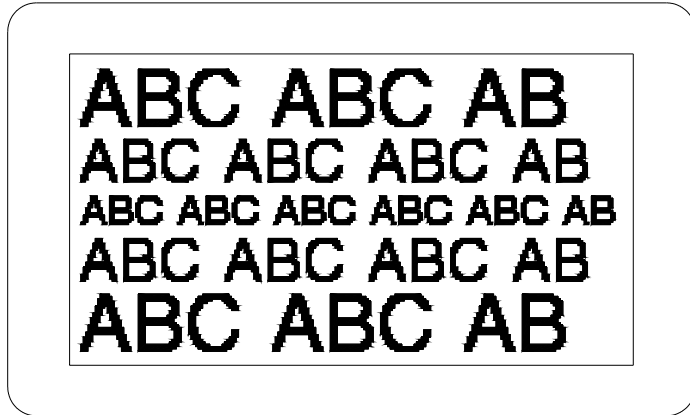

Figure 1.5 Model 663 and 665 16x40 LCD

1.15 Keypad

A sealed elastomer keypad comes standard on all stainless steel 60 Series indicators. A TTL alpha keypad is also available as an option on the model 663 controller. For more information on the alpha keypad option, please refer to the 60 Series Service Manual.

Detailed descriptions of each key and its associated function follow below.

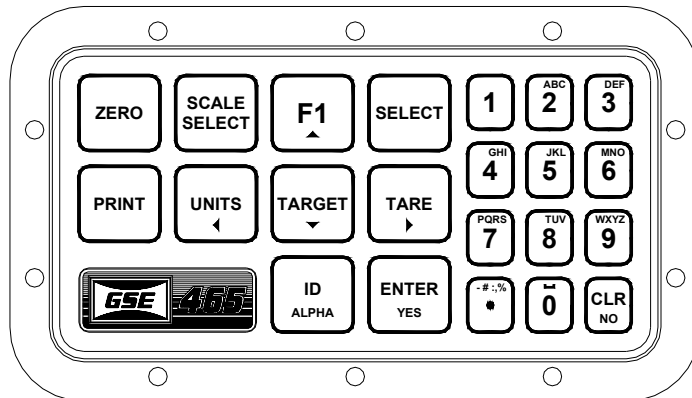

Figure 1.6 Model 465 Keypad

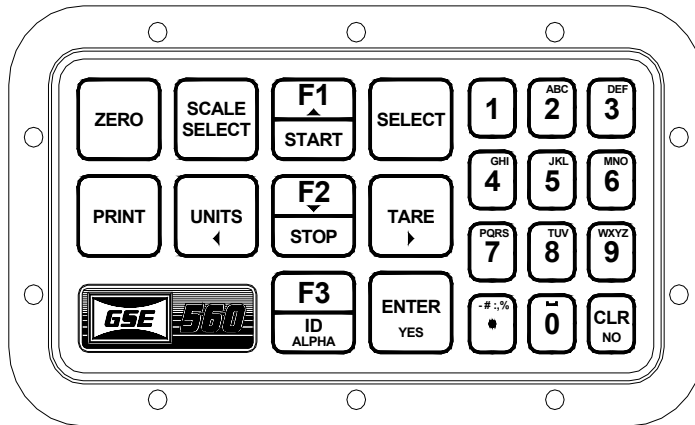

Figure 1.7 560 Series Keypad

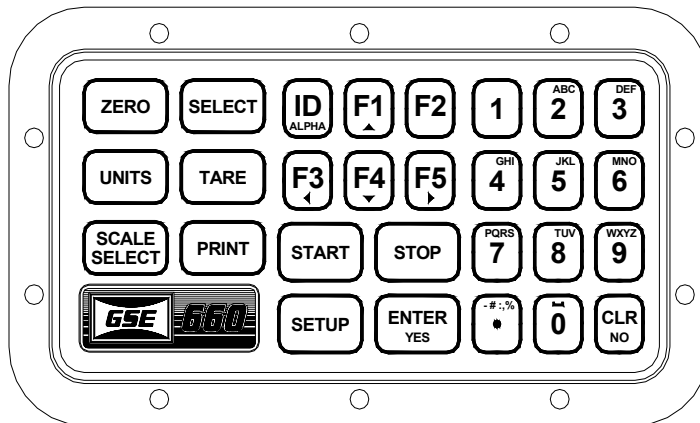

Figure 1.8 660 Series Keypad

Table 1.5 Model 465, 560 Series and 660 Series Keys and Descriptions

Key	Description
[ZERO]	Press [ZERO] to zero the current quantity/weight reading. When the meter is at Center Zero center-of-zero indication will appear on the upper line of the dot matrix display. If a Custom Unit's name is greater than 2 characters, the Center Zero indication is not displayed. If in the quantity mode, pressing [ZERO] will set the current mode to a gross zero quantity. If in the Weigh Mode, pressing [ZERO] sets the current mode to Gross Weight.
[UNITS]	Pressing [UNITS] from the Weigh Mode will toggle the displayed units through the available selections. Converted units are automatically rounded to the appropriate increment.
[SELECT]	Pressing [SELECT] will toggle you through the Net Weight, Tare Weight and Gross Weight or other enabled operating modes.
[TARE]	Pressing [TARE] by itself will perform an auto-tare. A Net Zero is then displayed. You can enter a known Tare weight by keying in the number and pressing [TARE]. In either case, the indicator will be placed in the Net Mode, unless you are in the Tare Mode.
[ENTER/YES]	Press the [ENTER] key following certain numeric entries. Doubles as a [YES] key for answering operator prompts.
[PRINT]	Press to send data to a printer, computer or other device.
[ID/Alpha]	Used for entering ID numbers.
[F1]	The [F1] key is used as an up arrow key for scrolling or as a function key (such as accessing a menu or starting a process). Not available on Model 460.
[F2]	The [F2] key is used as a function key (such as accessing a menu or starting a process). 560 and 660 Series only. Not available on Model 460 or Model 465.
[F3]	The [F3] key is used as a left arrow key for scrolling or as a function key (such as accessing a menu or starting a process). Not available on Model 460 or Model 465.
[F4]	The [F4] key is used as a down arrow key for scrolling or as a function key (such as accessing a menu or starting a process). Not available on 460 Series or 560 Series.
[F5]	The [F5] key is used as a down arrow key for scrolling or as a function key (such as accessing a menu or starting a process). Not available on 460 Series or 560 Series.
[TARGET]	Only available on the Model 465. Used as a function key and a down arrow key.
[START]	The [START] key is used as a function key. 560 and 660 Series only. Not available on 460 Series.
[STOP]	The [STOP] key is used as a function key. 560 and 660 Series only. Not available on 460 Series.
[SETUP]	The [SETUP] key is used as a function key. 660 Series only. Not available on 460 Series or 560 Series.
0 - 9 & .	Press the numeric keys to enter numeric values 0 through 9. Press [.] to establish a decimal point or perform an accumulation in the weigh or count mode. Not available on Model 460.

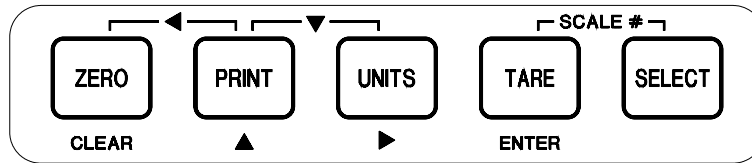

Figure 1.9 Model 460 Keypad

Table 1.6 Model 460 Keys and Descriptions

Keypress	Gross/Net	Qty	Other Modes
[ZERO / CLEAR]	Zero Scale	Zero Quantity	ZERO * CLEAR**
[PRINT]	Print custom transmit	Print custom transmit	Character Entry
[UNITS]	Toggle though enabled units	N/A	Space
[TARE / ENTER]	Tares Scale	Tares Scale	ENTER
[SELECT]	Selects Parameters	Selects Parameters	SELECT
Multiple Key Combinations			
[ZERO] + [PRINT]	left arrow	left arrow	left arrow
[ZERO] + [TARE]	N/A	N/A	Clear Entry
[ZERO] + [UNITS]	N/A	N/A	N/A
[PRINT] + [UNITS]	down arrow	down arrow	down arrow
[TARE] + [SELECT]	Scale Select	Scale Select	Move backwards
[UNITS] + [SELECT]	Performs an Accumulation	Performs an Accumulation	ENTER
[UNITS] + [TARE]	N/A	N/A	N/A
[PRINT] + [TARE]	N/A	N/A	N/A
* = No entry in progress ** = entry in progress			

2 Installation

This section outlines the basic installation of the 60 Series instruments. Please take the time to review these important guidelines.



WARNING: RISK OF ELECTRICAL SHOCK! SERVICE OF THE INDICATOR SHOULD ONLY BE PERFORMED BY AUTHORIZED SERVICE PERSONNEL.



If the 60 Series indicator is being plugged into an outlet, it must have an earth ground. Make sure the supply voltage from the outlet meets the requirements of the indicator.

2.1 Table top or wall mounting

All models excluding the model 663 have been designed with a swivel bracket, which lets you tilt the instrument face to any desired angle. When the instrument is placed on a table, the non-slip rubber feet prevent scratching and slipping across the surface when keys are pressed.

2.1.1 Model 460 Outline drawing

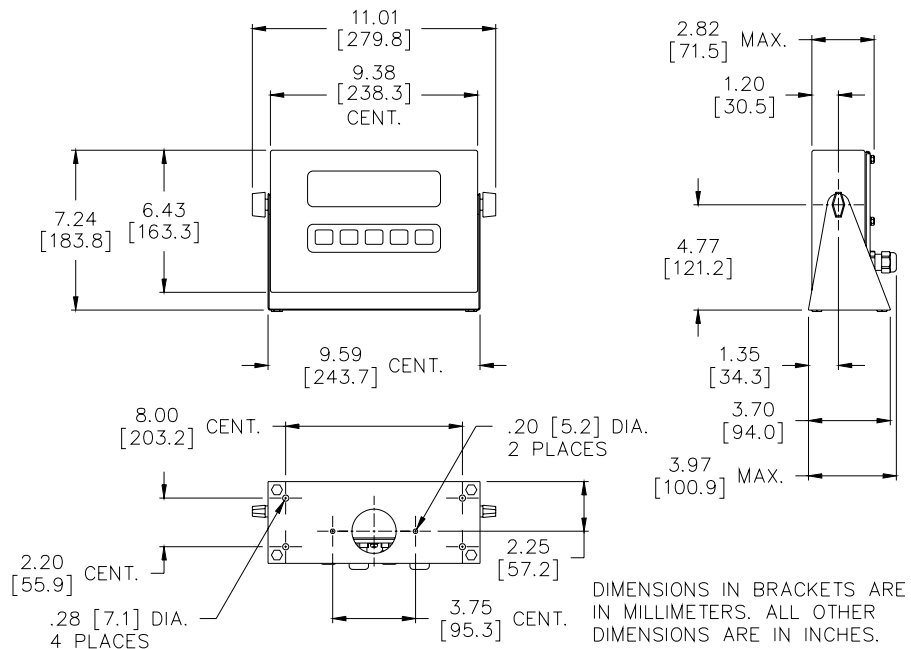

2.1.2 Model 465, 560, 562, 660, 662 Outline drawing

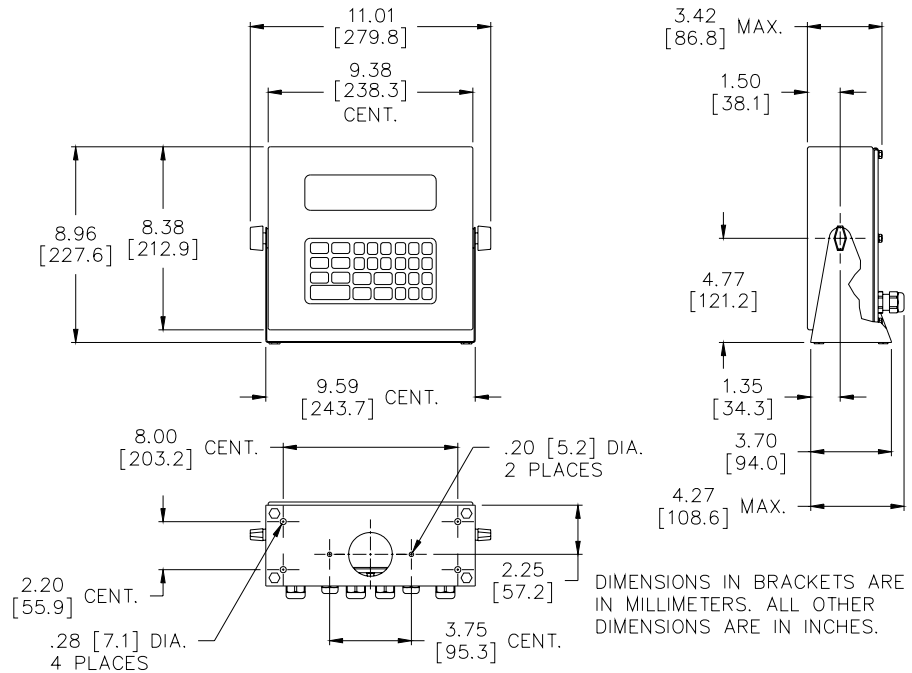

2.1.3 663 Outline drawing

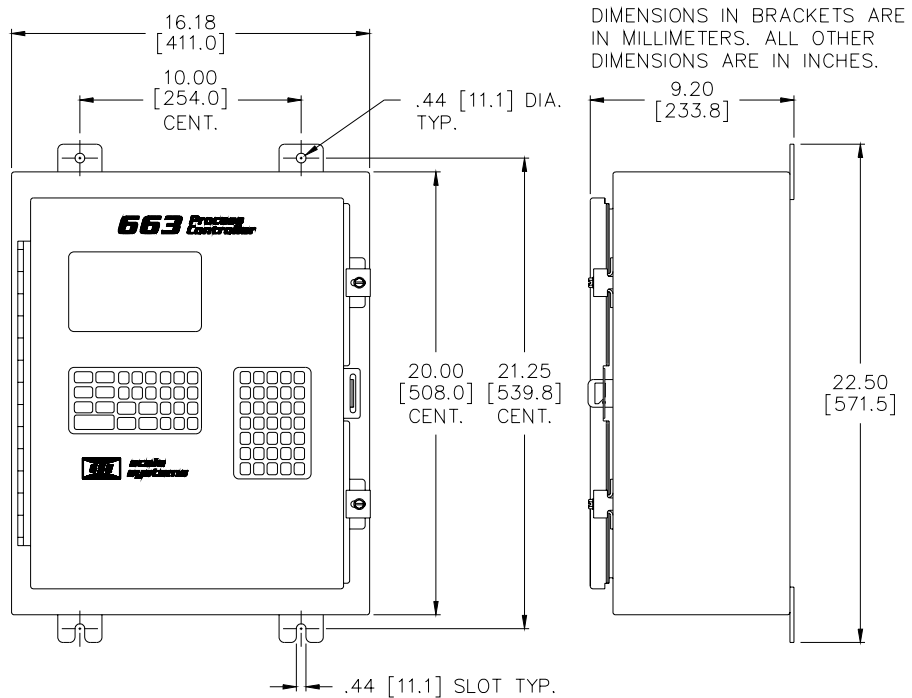

2.1.4 663 Big box outline drawing

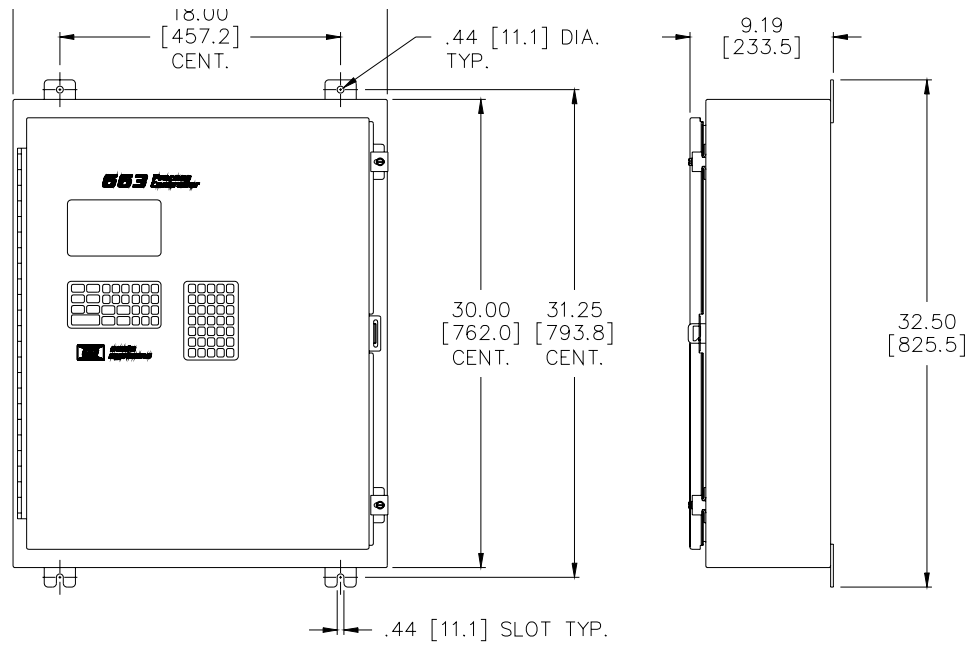

2.1.5 665 Outline drawing

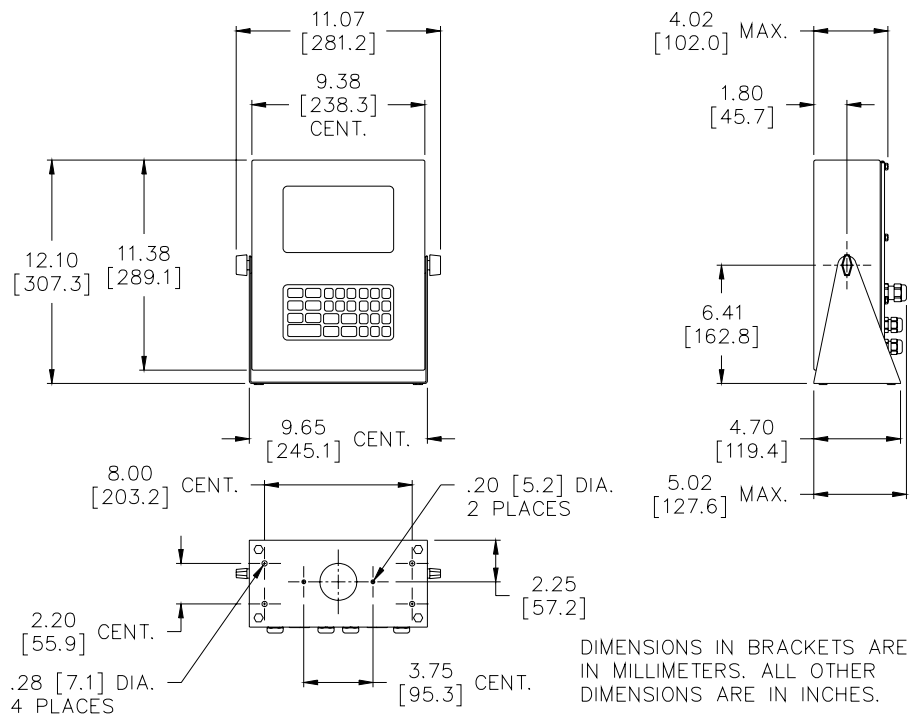

2.2 Panel mounting

All models excluding the Model 663 are available in panel mount versions. When properly installed, the units are suitable for wash-down environments. The panel-mount version functions identically to the table top version. The only difference between the two package types is the mechanical aspects of the enclosure and the positioning of the main board and display. Refer to the 60 Series Service Manual for further panel mount version installation procedures and available options.

2.2.1 Model 460 outline drawing

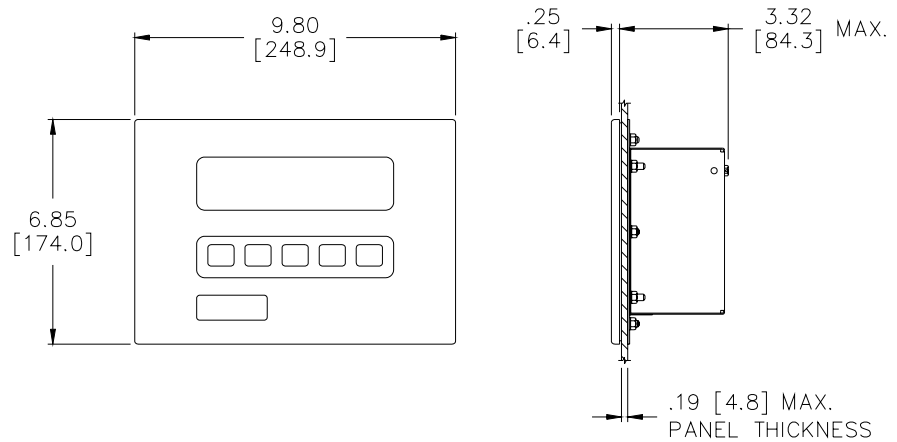

DIMENSIONS IN BRACKETS ARE IN MILLIMETERS. ALL OTHER DIMENSIONS ARE IN INCHES.

2.2.2 Model 460 panel mount cutout

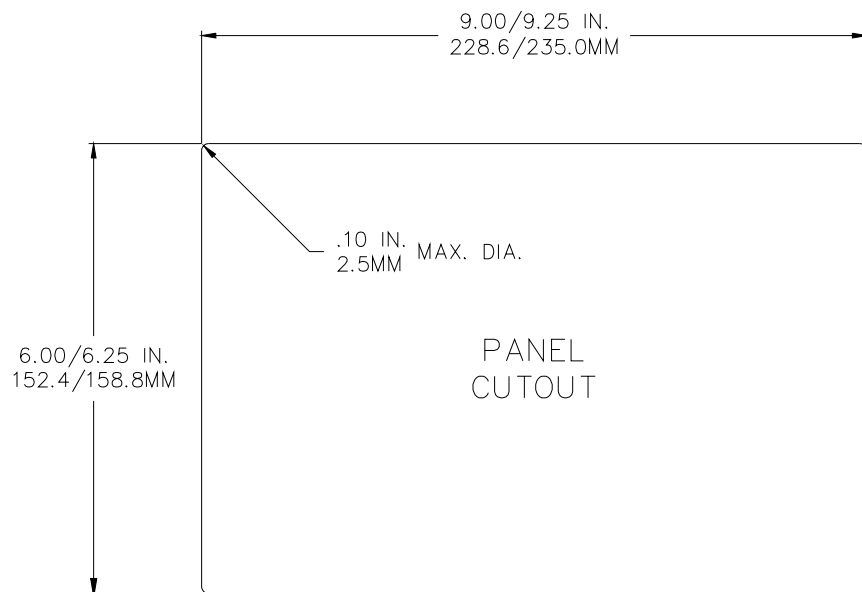

2.2.3 Model 465, 560, 562, 660, 662 panel mount outline drawing

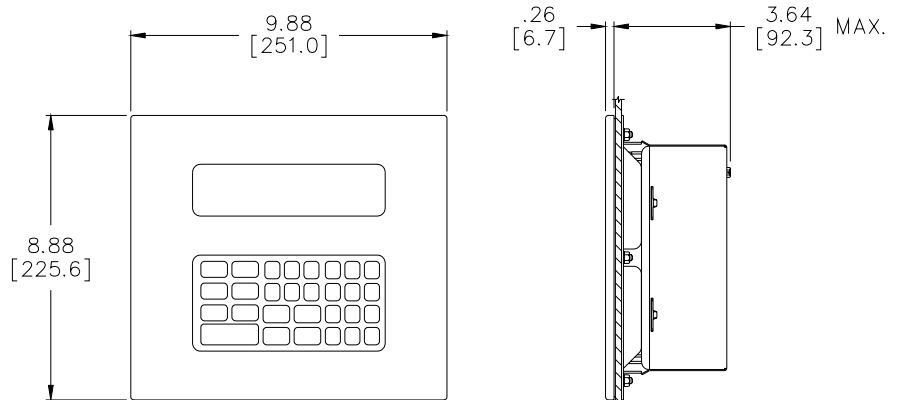

DIMENSIONS IN BRACKETS ARE
IN MILLIMETERS. ALL OTHER
DIMENSIONS ARE IN INCHES.

2.2.4 Model 465, 560, 562, 660, 662 panel mount cutout

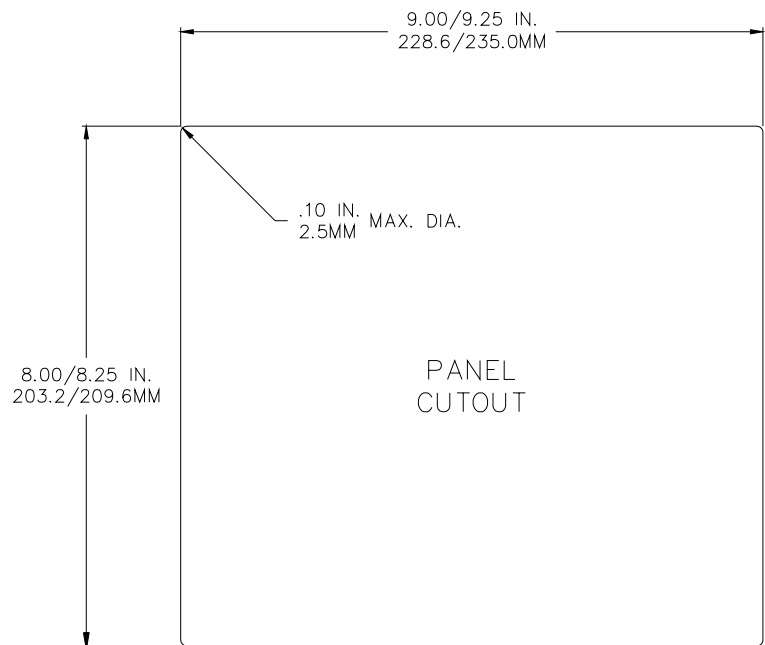

2.2.5 Model 665 panel mount outline drawing

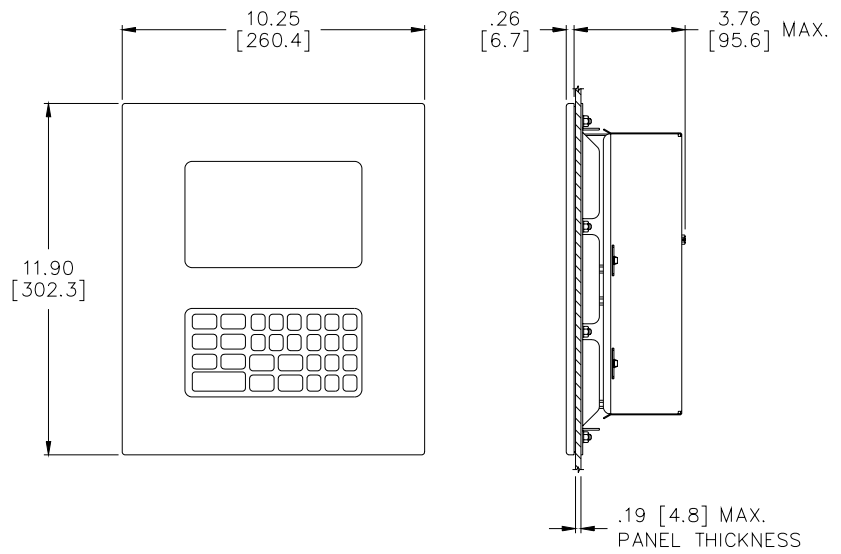

2.2.6 Model 665 panel mount cutout

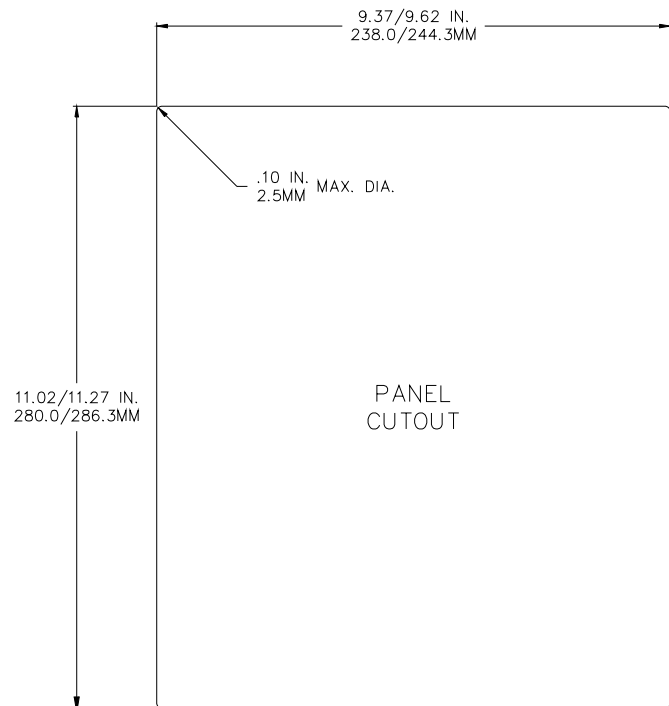

3 Operation

The 60 Series indicators can operate in a variety of modes such as check-weighing, parts counting and filling etc. The functions described in this section are not available until enabled within the setup parameters. Contact your GSE distributor to configure the indicator for a specific operation.

3.1 Entering a tare value (model 460)

If a tare value is known, it is possible to enter that value into the tare register if the setup parameter has been enabled.

1. From the gross or net mode press the [SELECT] key until tare is displayed.
2. Use the [PRINT] key to scroll in the first number.
3. Press the [UNITS] key to move to the next digit.
4. Repeat steps 2 and 3 until the desired number is showing on the display.
5. Press the [TARE] key to accept the entered tare value.

3.1.1 Entering a tare value (all models excluding model 460)

If a tare value is known, it is possible to enter that value into the tare register if the setup parameter has been enabled.

1. Enter the known tare value with the numeric keys and press [TARE]. The display will access the net mode

3.1.2 Time/Date (clock feature)

The time and date feature is stored as non-volatile (time/date setting will not be lost when the unit power is reset).

The time and date can be accessed from the weigh mode with the [SELECT] key if the time/date parameter has been enabled. Time and date can be accessed via the communication port by sending 11%*s*.

3.1.3 Entering the Time / Date (excluding model 460)

1. From the weigh mode, press [11] [SELECT] to access the time and date.
2. Press [ENTER] to invoke the date prompt.

3. A new date is entered by keying in "MM.DD.YY" (or "DD.MM.YY" if international format was selected) followed by the [ENTER] key.

Month, day and year entries must be separated by decimal points. Leading zeroes need not be entered.

For example, if you enter "4.1.96" and press [ENTER] the date is set to 04/01/96. If the date is entered improperly, the prompt try m.d.y (or try d.m.y for international format) is displayed. The word *Date* will then be displayed. Press [ENTER] if the date is correct and move to the Time setting mode.

4. The new time is entered by keying in "HH.MM.SS" in a 24-hour format. Hours and minutes entries must be separated by a decimal point. Seconds entry is optional, and if omitted, they are set to zero. To specify seconds, it also must be separated from minutes by a decimal point. Leading zeroes need not be entered. For example, if you enter "8.9.45" and press [ENTER], the time will be set to 08:09:45; if you enter "15.02" and press [ENTER] the time is set to 15:02:00. If time is entered improperly, the prompt try h.m.s is displayed. The word *Time* will then be displayed. Press [ENTER] if the time is correct.

3.1.4 Entering the time / date (model 460)

1. From the weigh mode, [SELECT] until the time/date is displayed.
2. Press [ENTER] to invoke the date prompt.

The [ENTER] key may be pressed to bypass the date entry. A new date is entered by keying in "MM.DD.YY" (or "DD.MM.YY" if international format was selected) followed by the [ENTER] key. Month, day and year entries must be separated by decimal points. Leading zeroes need not be entered. Using the combination of the [PRINT] and [UNITS] keys, enter the in the date. If the date is entered improperly, the prompt try m.d.y (or try d.m.y for international format) is displayed. The word *Date* will then be displayed.

3. Press [ENTER] if the date is correct and [ENTER] again to move to the Time setting mode.
4. The [ENTER] key may be pressed to bypass the time entry.

The new time is entered by keying in "HH.MM.SS" in a 24-hour format. Hours and minutes entries must be separated by a decimal point. Seconds entry is optional, and if omitted, they are set to zero. To specify seconds, it also must be separated from minutes by a decimal point. Leading zeroes need not be entered. Use the [PRINT] and [UNITS] keys to enter time. If time is entered improperly, the prompt try h.m.s is displayed. The word *Time* will then be displayed. Press [ENTER] if the time is correct.

3.2 Parts Counting

The counting parameter must be enabled before using. Follow the instructions below for sampling and counting parts. A new sample must be performed for each unique part being counted. The indicator will not store the average piece weight.

3.2.1 Simple keypad sample (model 460)

Method 1: Sample 10 pieces (parts) and count additional parts

1. Press [SELECT] until Qty is displayed.
2. Place the empty container on platform (optional). If a container is not being used, skip this step and go to step 3.
3. Press the [TARE] key. The model 460 indicator will tare to a zero net weight.
4. Place 10 parts on the platform.
5. Press [TARE] to accept the sample.
6. Add additional parts to be counted. This number of parts added will be displayed.

Method 2: Sample and count a specific number of parts

1. Press [SELECT] until Qty is displayed.
2. Place the empty container on platform (optional). If a container is not being used, skip this step and go to step 3.
3. Press the [TARE] key. The model 460 indicator will tare to a zero net weight.
4. Place the specified number of parts on the scale. (**Add XX**, "XX" being the number of parts to sample) or key in the number of parts being sampled by pressing the [PRINT] key until the first digit is displayed. Use the [UNITS] key to move to the next digit. Continue using the [PRINT] and [UNITS] keys until the desired sample size is displayed and press [TARE].
5. Press [TARE] to accept the sample. (Or add any number of parts, key in the number added, then press [TARE]).

Method 3: Sample and count with a known container weight

1. Press [SELECT] until Qty is displayed.
2. Place the full container of parts on the weigh platform.
3. Press the [TARE] key.
4. The indicator will tare to a zero net weight. The display shows the current net weight and prompts *Add 10*
5. Remove the specified number of parts from the container.
6. Press [TARE].
7. The indicator calculates the piece weight of the sample parts removed.

8. Key in (or bar-code scan) the tare weight of the container.
9. Add the sample parts back in that were removed.
10. The displayed quantity then is the total number of parts in the container.

3.2.2 Negative piece sampling (model 460)

In order to perform a negative sample routine, the parts must have been sampled previously and the average piece weight must be accessible.

1. Access the quantity mode by pressing [SELECT].
2. Place a full or partially full container of parts on the scale, and press [SELECT] to access the quantity mode. The model 460 indicator will perform an auto-tare resulting in a zero net weight.
3. The display will prompt you to **Add:XX** where "XX" is the sample quantity of parts (sample size). Disregard the **Add:XX** prompt, assume **Take:XX**, and remove the requested number of parts.
4. Press the [TARE] key.
5. If the sample's total weight was sufficient, the piece weight will be calculated and the sample quantity will be displayed. Otherwise, you may be prompted to "Take" additional parts.
6. Key in the tare weight of the empty container with the [PRINT] and [UNITS] keys and add the parts removed for sampling back into the container. The quantity displayed will be the total quantity of parts in the container.
7. If the weight of the sample removed is not detectable or barely detectable, the message *Code 32 ADD MORE!* is displayed briefly. This actually means "Take" if a negative sampling is to be performed. The model 460 indicator does not know if the operator intends to perform a positive or a negative sampling if no weight is removed. This prompt indicates that more weight must be removed adding to the overall sample weight. This will most often occur when the [TARE] key is pressed without taking out any parts. If the parts were in fact taken from the scale, either the parts are too light to count on that capacity platform or a much larger quantity of parts must be hand counted out in order to perform the sample.

3.2.3 60 Series (excluding model 460)

3.2.4 Simple keypad sample

Method 1: Sample 10 pieces (parts) and count additional parts

1. Press [SELECT] or 30 [SELECT] to access the quantity mode (QTY).
2. Place the empty container on platform (optional). If a container is not being used, skip this step and go to step 3.
3. Press the [ENTER] key. The indicator will tare to a zero net weight.
4. Place 10 parts on the platform.

5. Press [ENTER] to accept the sample.
6. Add additional parts to be counted. This number of parts added will be displayed.

Method 2: Sample and count a specific number of parts

1. Press [SELECT] or 30 [SELECT] to access the quantity mode.
2. Place the empty container on platform (optional). If a container is not being used, skip this step and go to step 3.
3. Press the [ENTER] key. The indicator will tare to a zero net weight.
4. Place the specified number of parts on the scale. (**Add XX**, "XX" being the number of parts to sample) or key in the number of parts being sampled by keying in the amount and pressing the [ENTER] key.
5. Press [ENTER] to accept the sample. (Or add any number of parts, key in the number added, then press [ENTER]).

Method 3: Sample and count with a known container weight

1. Press [SELECT] or 30 [SELECT] to access the quantity mode.
2. Place the full container of parts on the weigh platform.
3. Press the [ENTER] key.
4. The indicator will tare to a zero net weight. The display shows the current net weight and prompts *Add 10*
5. Remove the specified number of parts from the container.
6. Press [ENTER].
7. The indicator calculates the piece weight of the sample parts removed.
8. Key in (or bar-code scan) the tare weight of the container.
9. Add the sample parts back in that were removed.
10. The displayed quantity then is the total number of parts in the container.

3.2.5 Negative piece sampling

In order to perform a negative sample routine, the parts must have been sampled previously and the average piece weight must be accessible.

1. Access the quantity mode by pressing [SELECT] or 30 [SELECT].
2. Place a full or partially full container of parts on the scale, and press [SELECT] or 30 [SELECT] to access the quantity mode. The 60 Series indicator will perform an auto-tare resulting in a zero net weight.
3. The display will prompt you to **Add:XX** where "XX" is the sample quantity of parts (sample size) set by parameter P182. Disregard the **Add:XX** prompt, assume **Take:XX**, and remove the requested number of parts. The weight difference of the requested number of parts is then calculated by the 60 Series indicator.

4. Press the [ENTER] key.
5. If the sample's total weight was sufficient, the piece weight will be calculated and the sample quantity will be displayed. Otherwise, you may be prompted to "Take" additional parts. The exact prompts will depend on whether the auto-enhance and/or minimum accuracy assurance features have been enabled.
6. The minimum amount of weight required for the sample routine to meet the selected accuracy requirements for the specified scale capacity is considered. Continue to enhance, as desired. Key in the tare weight of the empty container, add the parts removed for sampling back into the container. The quantity displayed will be the total quantity of parts in the container.
7. If the weight of the sample removed is not detectable or barely detectable, the message **Code 32 ADD MORE!** is displayed briefly. This actually means "Take" if a negative sampling is to be performed. The 60 Series indicator does not know if the operator intends to perform a positive or a negative sampling if no weight is removed. This prompt indicates that more weight must be removed adding to the overall sample weight. This will most often occur when the [ENTER] key is pressed without taking out any parts. If the parts were in fact taken from the scale, either the parts are too light to count on that capacity platform or a much larger quantity of parts must be hand counted out in order to perform the sample.

View the average piece weight

From the QTY mode, press [SELECT] once. The display will show APS and then flash the last sampled average piece weight. This value cannot be altered.

Press the [SELECT] key to exit the average piece weigh mode. Continue to press [SELECT] until the desire weigh mode parameter is displayed.

3.3 Accumulation Mode

60 Series controllers offer three main memory registers into which weighing data may be accumulated. The three registers are the Gross Total, Net Total and the Quantity Total.

3.3.1 Performing Accumulations

1. Enter the desired "accumulation mode" either by pressing the [SELECT] key until one of the Accumulation Modes appears on the display or key in one of the accumulation parameters directly. Refer to [Table 3.1](#) on page [33](#).

- Once in an accumulation mode, press [UNITS] + [SELECT] on the Model 460 or [.] [ENTER] on all other 60 Series indicators to add the displayed value to the accumulated total.

Accumulate operations are motion delayed. If motion is occurring when an accumulation is requested, the Mot'n Delay prompt is displayed until motion ceases. If motion does not stop, press [CLR] to abort the accumulation.

There are six accumulation modes with corresponding mode numbers as shown in Table 3.1. When an accumulation is made, both the gross and net totals are affected. After an accumulation occurs, these values are frozen at their new accumulate total values until the gross weight returns to zero. The weight must return to zero before another accumulation is allowed. At that time, these values again resume their active state. This feature prevents double accumulations. A *CLEAR WGHT* prompt appears to warn of such situations.

3.3.2 Initializing Accumulation Totals

The accumulation registers may be reset to a new number. This would permit you to enter a total from the previous day or shift to continue the accumulation, or to reset the number to "0".

- Access the accumulation mode by keying in the single or two-digit mode number from Table 3.1 and press [SELECT] (not available on the Model 460).
- The [ZERO] + [ENTER] keys on the Model 460 or the [CLR] key on all other 60 Series may be used to reset both the net and gross totals to zero.
- The prompt *CLEAR ACS?* will appear briefly followed by *ENTER = CLR!*. Press [ENTER] to complete the clearing or press any other key to abort the clear operation.

3.3.3 Accumulation Modes

Table 3.1 Accumulation Modes

Mode Number	Description
3	Gross Total (GrTOT)
6	Net Total (GrTOT)
9	Accumulation Counter (# Accum)
31	Quantity Total (QtTOT)

3.4 Absolute and Percent Checkweighing

The standard check-weigh operation is designed to check the weight of an item against a given standard or target weight. In the check weigh absolute mode, values are entered as target limits. In the check weigh percent mode, the values are entered based on a percentage. Both checkweighing methods are available on all indicator models.

3.4.1 Set the high and low limits (excluding model 460)

1. Press [TARGET] or [F2] and "10.00 Hi" (by default) will be displayed. To accept the value of 10 go to step 4.
2. Key in the desired high value weight and press [ENTER] or go to step 3 to accept the value of 10.
3. Press [ENTER] and "5.00 Lo" (by default) will be displayed.
4. Key in the desired high value weight and press [ENTER] or go to step 5 to accept the value of 5.
5. Press [ENTER] to save the entered values.

3.4.2 Use checkweigh mode (excluding model 460)

1. Press [F1] to start check-weighing
2. Add weight to the scale.
3. Press [TARGET] or [F2] key to stop check-weighing.



if your weight is greater than your high weight limit, "OVER" is displayed. If your weight is less than your low weight limit, "UNDER" is displayed. If your weight is between the High and Low limits, "GOOD" is displayed.

3.4.3 Set the high and low limits (model 460)

1. Press [SELECT] until "mName SETUP" is displayed.
2. Press [TARE] and "10.00 High" (by default) will be displayed. To change the value, go to step 3. To accept the value of 10 go to step 4.
3. Use the [PRINT] key to enter a number and [UNITS] key to move over 1 spot.
4. Press [TARE] and "5.00 Lo" (by default) will be displayed. To change the value, go to step 3. To accept the value of 5 go to step 5.
5. Press [TARE] to save the entered values.

3.4.4 Use checkweigh mode (model 460)

1. Press [SELECT] until "mName START" is displayed.
2. Press [TARE]. The display will return to the weigh mode.



to stop check-weighing, press [SELECT] until the gross mode display displayed.

if your weight is greater than your high weight limit, "OVER" is displayed. If your weight is less than your low weight limit, "UNDER" is displayed. If your weight is between the High and Low limits, "GOOD" is displayed.

3.5 Truck I/O

Used for vehicle weighing where product is being loaded or unloaded. Connect an external keyboard when using a Model 460.

3.5.1 Truck in

1. Weigh the vehicle in.
2. With the truck on the scale. Press [F1] and "Key In ID#" will be displayed.
3. Press [ENTER] for Automatic ID# or key in the ID number and press [ENTER].
4. The indicator flashes "*Weigh In*" and returns to the gross mode.
5. If a printer is connected, a ticket will automatically be printed.

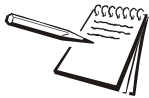

look at the printed ticket to find the trucks ID# if Automatic ID# is used.

3.5.2 Truck out

1. Weigh the vehicle out.
2. With the truck on the scale. Press [F1] and "Key In ID#" will be displayed.
3. Key in truck ID#.
4. Press [ENTER] prompt flashes "*Weigh Out*".
5. If a printer is connected, a ticket will automatically be printed.

3.5.3 Print ID's?

Prints all ID's in a row column with header format.

1. Press [TARGET] or [F2] and "*Print ID's?*" will be displayed. All stored ID numbers will be printed.
2. Press [ENTER] to print all stored ID numbers. After the ID numbers are printed, the indicator will return to previous display mode.

3.5.4 Clear one ID

Clears one record from the database.

1. Press [TARGET] or [F2] and "Print ID's?" will be displayed.
2. Press [CLR/NO] and "Clear One?" will be displayed.
3. Press [ENTER] and "ID to Delet" will be displayed.
4. Key in the ID number to be deleted and press [ENTER].
5. If the ID number is not stored in the database, "Not Found" will be displayed briefly. The indicator returns to the weigh mode.
6. Otherwise, if the ID number was found "Done" will be displayed briefly and the indicator will return to the weigh mode.

3.5.5 Clear all

Clears all records from the database.

1. Press [TARGET] or [F2] and "Print ID's?" will be displayed.
2. Press [CLR/NO] and "Clear One?" will be displayed.
3. Press [CLR/NO] and "Clear ALL?" will be displayed.
4. Press [ENTER] and "Clear Sure?" will be displayed.
5. Press [ENTER] to clear all records. After the database is cleared, the indicator will return to previous display mode.

NOTE: [CLR] will abort the process.

3.5.6 Store truck in tare weight

Make a permanent record in the database for a truck tare weight.

1. With the truck on the scale, press [F1] and "Key In ID#" will be displayed.
2. Press [TARE] and "Press tare or KeyIn" will be displayed.
3. Key in tare weight of the truck or press [TARE]. "Key In ID#" will be displayed.
4. Key in the truck ID number or press [ENTER] for automatic ID number.
5. The indicator flashes "Weigh In" and returns to the gross mode.
6. If a printer is connected, a ticket will automatically be printed.



look at the printed ticket to find the trucks ID# if Automatic ID# is used.

3.6 APW (average piece weight) lookup

A specific average piece weight may be recalled from a database. The average piece weight will be associated with an ID#.

3.6.1 Store APW

Use this method to store a specific APW to the database. A sample must be performed before this function can be used.

1. To store an average piece weight, Press [SELECT] until APW is displayed. Key in the average piece weight and press [ENTER].
2. From the gross weight, press [F1] and "Key In ID" will be displayed.
3. Key in the desired ID number.
4. Press [ENTER] and "store new#?" will be displayed.
5. Press [ENTER] to store the ID or [CLR] to abort.
6. Add sample parts (default value = 10) to the scale.
7. Press [ENTER] to store APW.

NOTE: [CLR] will abort the process.

3.6.2 Get APW

Retrieve a specific APW from the database.

1. Press [F1] and "Key In ID" will be displayed.
2. Key in the ID number. If the ID# exists, "Found ID#" will be displayed briefly and then ID#.
3. The display will return to the QTY mode. Press [ENTER] to accept entry.
4. The piece weight register is updated with the associated value.



If the ID# does not exist you will be prompted to add default number of pieces to store a new APW.

NOTE: [CLR] will abort the process.

3.6.3 Print APW'S

Prints all stored records in row/column format.

1. Press [TARGET] or [F2] and "Delete ID# XXX?" will be displayed.
2. Press [CLR/NO] to advance to print mode.

3. Press [ENTER] to print stored APW's in row/column format.
4. Indicator returns to the gross mode.

3.6.4 Clear one APW

Clears current record from the database.

1. Press [TARGET] or [F2] and "*Delete ID# XXX?*" will be displayed.
2. Press [ENTER] at the prompt to confirm deletion.



this will only remove the current APW from the database.

3.6.5 Clear all APW'S

Clears all records from the database.

1. Press [TARGET] or [F2] and "*Delete ID# XXX?*" will be displayed.
2. Press [CLR/NO] until "*Clear ALL?*" is displayed.
3. Press [ENTER] to delete all ID#s from the database and "*Clear SURE?*" will be displayed.
4. Press [ENTER] at the prompt to confirm deletion.
5. Indicator returns to the previous display mode.

3.7 Fill (Batching)

The fill program is used for single-speed or dual-speed filling operations. The dual-speed fill operation allows for both a fast and a slow fill mode. During a fast-fill, setpoints 1 and 2 are activated. During a slow-fill or single-speed fill, only setpoint 1 is activated.

The standard batch program is used for batching up to three separate items. Ingredients 1 through 3 use setpoints and pre-acts 1 through 3 respectively. Ingredients are batched one at a time.

When the fill application file is being loaded the following prompts will be displayed:

"*Pacts Y/N?*" - Press [ENTER] if preacts will be used or [CLR] for no preacts.

"*Dribl Y/N?*" - Press [ENTER] if dribble will be used or [CLR] for no dribble.

The file will load the answers to the questions and the following prompt will be displayed:

"*#Spts 1to4*" - chose the number of setpoints that will be used and press [ENTER].

The file will load the number of setpoints chosen and go to the weigh mode.

3.7.1 Setup Outputs

Settings for setpoints preact, and dribbles.

Setpoints

1. Press [TARGET] or [F2] and "0.00 SP 1" will be displayed.
2. Key in Setpoint value and press [ENTER].

Preact

If preact was chosen previously, use the following steps:

" 0.0 PAct." Will be displayed. Key in Preact value (if enabled), zero (0) for no preact and press [ENTER].

Dribble

If dribble was chosen previously, use the following steps:

" 0.0 PAct." Will be displayed. Key in Preact value (if enabled), zero (0) for no preact and press [ENTER].

1. Repeat the steps above for each setpoint your systems has.
2. The indicator will return to the weigh mode.

3.7.2 Batching

1. Press [ZERO] to zero the indicator
2. Press [F1]. Fill until the target is met. "Done" will be displayed when cycle completes
3. Empty the scale



if the weight is greater than the high limit then the prompt "OVER" is displayed. If the weight is less than the low limit the prompt "UNDER" is displayed. If the weight is between the high and low limits then prompt "GOOD" is displayed.

4 Troubleshooting

This chapter of the 60 Series user instructions manual provides information on error messages and troubleshooting. Some information in this chapter refers to parameters that are not discussed in this guide. They are provided as a quick reference to problems and solutions. Please consult your indicator support group for additional information.

All 60 Series error messages are listed below in numerical order. The leading two digits will appear on the numerical portion of the display, and the message will appear on the two lines of dot matrix display. Following each message is a summation of possible causes and probable remedy.

4.1 Information and error messages

4.1.1 Operational Mode Error Messages

Error	Description
02 UnderLoad!	Input signal less than negative full scale. Check the load cell connections. If a 4-wire load cell cable is being used, check that the sense jumpers are in place.
03 Over-Load!	Input signal is greater than 104% of positive full scale. Use same check as for underload.
04 # > Dsply	Number to be displayed will not fit within 6 digits. This will not normally occur for the Gross, Net or Tare Weights but may result while displaying the accumulated totals if the amount exceeds 999,999. Clear the totals or settle for only being able to transmit the totals.
05 Zero> Max.!	An attempt was made to zero out more than allowed per the zero range parameter setting. Use the [TARE] key for subtracting off container weights or if large dead load is always to be present.
06 Tare>F.S.!	Tare entry was greater than full scale. Most likely the entered tare value was incorrect.
07 Tare < 0 !	Negative tare attempted, but not allowed.
08 CheckConn.	Displayed if the signal into the A/D is +/- 2 times the Full Scale signal. This is effectively taken into consideration when the information sent to the microprocessor from the A/D is +/- twice the allowable full scale reading.

4.1.2 Setup Mode Error Messages

Error	Description
10 Entry>Max!	An entry was made which had more characters than allowed.
11 WRONGCODE!	The incorrect access code was entered, thus preventing changes. In order to access the Setup Mode, either the proper code must be entered or [ENTER] must be pressed alone (to view selections without making changes).
12 No Mods!	The Setup Mode is being accessed, but changes are prevented.
13 OutOfRange	An entry made for a selection was beyond the range of valid choices.
14 Must Keyin	The choice for the current parameter must be keyed in.
15 Size>3999!	The size of a Custom Transmit setup has exceeded the limit.
16 CHECK JUMPR	A programming operation was attempted when the program jumper is installed. Installation of this jumper prohibits programming changes.

4.1.3 Hardware Problem Error Messages

Error	Description
17 A/D BAD!	The processor has detected a problem with the A/D chip. Contact your GSE distributor.
18 BufSzMax!	The accumulative total buffer size for both the TX and RX buffers of all four COMM ports is 4096 bytes.
20 Deflt A/D	This message appears for 1 second. It will be displayed if the A/D calibration data gets corrupted. Contact your GSE distributor.
21 WriteNVErr	Error reading data from the EEPROM.
22 ReadNVErr	Error writing data to the EEPROM.
23 CheckNVPar	Supplementary error message for above errors.
24 NVParFull!	The setup being attempted requires more EEPROM than is currently installed.
25 DefltSetup	Upon power-up the indicator has not found the proper codes. Therefore all parameters have been reset to factory default values.
26 Bad Setup	The stored data has a checksum error. Check all parameters or re-load setup.
27 RE-BOOT!	The indicator cannot use the EEPROM for data storage, so it is attempting to power-up again to cure the problem.
28 NoRAMAVAIL	The current setup requires more RAM than is currently installed. Contact your dealer or the manufacturer.
29 PIN error	This message will appear on power-up or setup if the E2 is corrupted in the PIN section. Check E2 for problems.

4.1.4 General Error Messages

Error	Description
99 Can't Set!	An attempt to enter a value for a parameter which is not field changeable, such as the serial numbers or the audit trail counter results in this message.
-- Cksumerror	Upon each power-up, the indicator tests the integrity of its EPROM. If the result is not correct this message is displayed and the Indicator is not usable.
EntryError	This error message is the most commonly used. The primary causes are entering a value preceding a key (such as [ZERO]) which is not allowed, entering alpha data for a numeric selection, or entering a fractional value for an entry which only accepts whole numbers. Occurs in Setup Mode or an operational mode.

4.1.5 Communications Error Messages

Error	Description
ovrnXerror	This indicates an over run error where an additional character was received while the receive buffer of the indicator is full, and thus the extra received character will be lost.
frmgXerror	This indicates that the stop bit of a received character did not occur when it was expected. This could be the result of an incorrect baud rate, incorrect number of data bits, or incorrect parity setting.
portX error	The indicator did not check the receive data register in time, thus missing a character. If this error should occur, please notify your GSE distributor or the factory.
tx on hold	This will occur if a data transmission is held up for two seconds or more due to a de asserted handshake.
tx abort	This occurs if the [CLR] key is pressed when the tx on hold error message is shown.
tx con'd	This will appear briefly when the handshake is re asserted after the tx on hold message occurs.

4.2 Other troubleshooting concerns

4.2.1 Data transmission

If a data transmission of any weight-related numeric data such as Gross, Net or Tare is sent as dashes, an overload or underload (negative overload) condition was in effect. Remove the cause of the overload (or underload) and repeat the transmission.

4.2.2 Displayed weight

If an overload or underload occurs due to an electrical overstress (EOS) normally due to lightning or ESD discharge, then press the [CLR] key. The message wait 1 will appear for about 1 second. The A/D converter will then be reset and the system should again be functional. If not, power down for a few seconds. If the indicator still does not work properly after power-up, check the load cell or platform wiring. If okay, permanent damage may have occurred, most likely to the instrument amplifier.

4.2.3 Service

There are no user serviceable items in the GSE 60 Series. Service must be performed by a qualified service technician only. Attempts to service this instrument by unqualified personnel may void the warranty.

Avery Weigh-Tronix



Avery Weigh-Tronix USA

1000 Armstrong Dr.

Fairmont MN 56031 USA

Tel:507-238-4461

Fax:507-238-4195

Email: usinfo@awtxglobal.com

www.wtxweb.com

Avery Weigh-Tronix UK

Foundry Lane,

Smethwick, West Midlands,

England B66 2LP

Tel:+44 (0) 8453 66 77 88

Fax: +44 (0)121 224 8183

Email: info@awtxglobal.com

www.averyweigh-tronix.com